

Section VI. Technical Requirements (including Implementation Schedule)

Table of Clauses

A. Background.....	3
1. The Purchaser.....	3
2. Background Information	4
3. Project Objectives	10
4. Project Scope and Other Requirement.....	11
B. Business Function and Performance Requirements	18
1. General Requirements to Be Met by the System.....	18
2. Acronyms Used in These Technical Requirements.....	19
C. Technical Specifications	29
1. Overall Requirements.....	29
2. ICT Infrastructure	30
3. e-Portal.....	86
4. Content Development and Management	117
5. Teacher Training	142
6. Project Implementation Service.....	164
D. Implementation Schedule.....	167
E. Required Format of Technical Bids.....	168
1. General Requirements	168
2. Technical Proposals	168
3. Documentary Evidences.....	169
F. Attachment	173

Technical Requirements

A. BACKGROUND

1. The Purchaser

The Ministry of Education of Colombia (MOE) is the national executive ministry of the Government of Colombia responsible for evaluating and defining educational policies and guidelines of the Colombian people.

Its mission is to grant the right to education with equity, quality and effectiveness criteria to educate honest, competent, accountable citizens, capable of building a happy, fair, productive, competitive, supportive and proud-of-itself society.

The Vision 2014 states that Colombia is one of the countries with the best quality of education in Latin America, will significantly contribute to reduce the equity gaps and will be a model of efficiency and transparency at national and international level.

The Ministry of Education of Colombia is committed to constantly establishing, implementing and improving the integrated management system(SIG), by articulating in its processes and services in a harmonious and complementary fashion in terms of compliance with legal requisites and quality management components, environment management, internal control and administration development.

The latter is in order to assure efficiency, efficacy, effectiveness and transparency of the institutional and social objective accomplishment to guarantee the satisfaction of customers and interested parties.

The purpose of SIG allows for orienting and following up compliance with the policy goes as follows:

- (a) Augment customer satisfaction levels.
- (b) Reinforce service supply, led towards improving coverage, quality, efficiency and relevance of education.
- (c) Underline the performance of macro processes established within the Ministry of Education of Colombia.
- (d) Grant availability, efficient use of financial resources availability and human resource competence.

- (e) Highlight application of self-control and evaluation mechanisms to allow for continuous improvement.
- (f) Guarantee citizen participation and social control mechanisms on the actions performed by the Ministry of Education of Colombia.
- (g) Improve environment performance by the Ministry of Education of Colombia and prevent

The Ministry of Education of Colombia is the Project Executing Agency for the Project.

2. Background Information

Elementary education in Colombia is obligatory and includes Grades 1 through 5. It constitutes the first cycle of basic education. Establishments providing this type of education have traditionally been called *escuelas* (schools) or *escuelas primarias* (primary or elementary schools), but now they are generally incorporated into larger establishments providing secondary education as well. There are no specific requirements for admission to this stage of education other than having attended the transition grade.

The minimum educational requirement for Teachers in Colombia, according with current policy are: to have professional degree by a higher education institution or to be graduated of "Escuela Normal Superior", in both cases, the applicants overcome the Merit Contest examination that is acknowledged for that purpose.

At the elementary level, students receive a minimum of 25 hours of instruction per week, which amounts to a minimum of 1,000 hours per school year.

Before the General law of education came into effect in 1994, the curriculum for elementary education was organized around seven major subject areas. Currently, the core of the curricula for elementary, lower secondary and upper secondary education consists of the so-called obligatory and fundamental areas (*áreas obligatorias y fundamentales*). Current legislation does not dictate the exact distribution of hours, which is determined by Schools, but it does stipulate that the subjects taught as part of the obligatory and fundamental areas must account for a minimum of 80 per cent of total instructional hours.

Options within the obligatory areas and possible additional subjects are chosen and developed by schools. The selection is based on regional demands and the resources available. The local secretariats of education are responsible for aiding individual institutions in this process. Before the curricula are implemented, they must be reviewed and approved by the secretariats.

PRIOR TO 1994			AFTER 1994				
UPPER SECONDARY	LOWER SECONDARY	ELEMENTARY	Core areas: <ul style="list-style-type: none"> • Spanish language • Mathematics • Social studies • Natural sciences • Aesthetic and manual education • Religion • Physical education 	Obligatory and fundamental areas: <ul style="list-style-type: none"> • Humanities, Spanish language and foreign languages • Mathematics • Social sciences, history, geography, political constitution and democracy • Natural sciences and environmental education • Artistic and cultural education • Religious education* • Physical education, recreation and sports • Education in ethics and human values • Technology and computing 	ELEMENTARY	LOWER SECONDARY	UPPER SECONDARY
			Additional areas: <ul style="list-style-type: none"> • Technology studies • Foreign language 				
		<ul style="list-style-type: none"> • Vocational initiation (in Grades 8 and 9) 					
		Additional subject: <ul style="list-style-type: none"> • Philosophy 					
		Specialization	Additional obligatory and fundamental areas: <ul style="list-style-type: none"> • Philosophy • Economic and political sciences 				
			Specialization				

* Religious education is offered by all educational establishments, but as of 1991, participation in this subject in public schools is optional.

In Colombian schools, passing to the next grade is based exclusively on internal assessments. In grades 3, 5 and 9, all children participate in the national SABER test which measure basic skills in the areas of language, mathematics, sciences and citizenship competencies. While the tests are a good indicator of the general level of skills and knowledge acquired by individual students, they have no direct impact on whether or not a student passes the grade.

Upon successful completion of elementary school, students may receive the certificate of completion of the fifth Grade of elementary instruction (Certificado al Quinto Grado de Enseñanza Primaria), but in most cases they receive only a transcript of all the courses completed and the grades achieved. All students are obliged by law to continue their education for another four years at the lower secondary level.

Despite numerous reforms, the overall structure of secondary education in Colombia has remained unchanged for several decades. Secondary studies last six years in total, with four years of instruction at the lower secondary level and two at the upper secondary level.

Lower secondary education represents the second cycle of basic education and the last stage of compulsory education. It encompasses Grades 6 through 9. The current most common name for lower secondary education is educación básica secundaria, but terminology may vary. The sole requirement for admission to lower secondary education is successful completion of elementary school. Establishments providing lower and upper secondary education (middle school-lower secondary 6, 7, 8, 9 grades and high school -upper secondary 10th and 11th grades) are usually called colegios, liceos, gimnasios or institutos.

The minimum educational requirement for lower secondary teachers is an undergraduate degree in education (licenciatura). Alternatively, teachers can hold

an undergraduate degree in a specific profession, preferably related to the subject they intend to teach, supplemented by additional Pedagogy Course.

Students enrolled in lower secondary education receive a minimum of 30 hours of instruction per week, amounting to a minimum of 1,200 hours per school year.

Prior to 1994, the lower secondary curriculum was organized around the core areas described in figure 2. Grades 6 and 7 were referred to as vocational exploration (exploración vocacional) since during this stage students would decide on their field of specialization. In Grades 8 and 9, the number of hours spent on general subjects was slightly decreased as students began specializing in their interest area. These last two years of lower secondary education were known as vocational initiation (iniciación vocacional). Currently, the curriculum for lower secondary education is structured around the same obligatory and fundamental areas as elementary education. The process and regulations for curriculum design are also the same as for the elementary level.

Passing to the next grade (and the next education level) is based exclusively on internal school assessments. In Grade 9, students again participate in the national SABER tests, administered in the subject areas of language, mathematics, sciences and civic competencies. The results of these examinations are not counted toward the students' final evaluation.

Completion of Grade 9 concludes the ten years (transition grade plus Grades 1 to 9) of obligatory education for Colombian youth. In most cases, those planning to continue their education at the upper secondary level proceed automatically to Grade 10, without being awarded a certificate. The evaluation of learning and promotion of students is based in Decree 1290 of 2009 this is a guideline of the institutional system to promotion for students. Each school defines their criteria for evaluate and promote the students from one grade to another, according to the law and the regulations. Some schools, however, may award:

- the certificate of basic secondary school studies (Certificado de Estudios del Bachillerato Básico)
- which can also be called certificate of completion of studies of basic education (Certificado de Término de Estudios de Educación Básica)
- and which was formerly known as the certificate of completion of the basic cycle of middle instruction (Certificado de Aprobación del Ciclo Básico de Enseñanza Media)

Prior to 1974, students who successfully completed Grade 9 with a specialization in commerce or industry were granted the title of experto (expert). Depending on personal inclinations and academic performance, students graduating from Grade 9

have three options: to continue their studies at the upper secondary level, to join a technical apprenticeship program or to seek employment.

Upper secondary education in Colombia is not obligatory and covers Grades 10 and 11. It is designed to consolidate and culminate the knowledge and skills acquired at previous levels. The only requirement for admission to upper secondary education is successful completion of Grade 9.

The minimum educational requirement for upper secondary teachers is an undergraduate degree in education (*licenciatura*). Alternatively, teachers can hold an undergraduate degree in a specific profession, preferably related to the subject they intend to teach, supplemented by additional teacher training.

This level of education is referred to as *educación media* or *educación media vocacional*, but the actual program of study is commonly referred to as *bachillerato* (literally the *baccalaureate*). The name of the credential or the title that students receive upon graduation is *bachelor*. The Spanish term *bachelor* is also used in reference to the person holding the title. The use of the word *vocational* (*vocational*) in connection with this level of education does not mean that the program provides occupational or technical training but rather that it allows students to specialize in either an academic or a professionally oriented area.

As at the lower secondary level, upper secondary students must receive a minimum of 30 hours of instruction per week, amounting to a minimum of 1,200 hours per school year. In practice, students generally receive 35 to 40 hours of weekly instruction.

The main areas of upper secondary curricula before and after 1994 are summarized in figure 2. The process and regulations for curriculum design are the same as for the elementary and lower secondary levels. Because of the specialized nature of upper secondary education in Colombia, traditionally the *bachillerato* programs have been described in terms of their type (*tipo*), modality (*modalidad*), specialty (*especialidad* or *opción*), or area (*área*). Over the years, the actual *baccalaureate* streams have changed little, but during different time periods the programs were officially grouped in different ways. In practice, time periods and nomenclature overlapped greatly.

In 1994, the General law of education divided *baccalaureate* programs into those with an academic orientation (*carácter académico*) and those with a technical orientation (*carácter técnico*).

- Academic orientation: academic core + academic specialization.

The purely academic stream offers general academic education plus the option to

specialize in a specific academic area such as natural sciences, social sciences, humanities, arts or foreign languages. Those who complete the program graduate with the title of bachelor académico (academic baccalaureate) and generally enter higher education. The academic baccalaureate has been by far the most popular among Colombian students. It is also the type of baccalaureate program that private schools tend to offer.

- Technical orientation: academic core + professionally oriented specialization

The technical stream aims to prepare students for entry into higher education as well as for employment in a specific field. The numerous areas of specialization include agriculture, commerce, finances, administration, ecology, industry, computing, mining, health, recreation, tourism, sports and others as determined by regional and labor market demands. Graduates from all modalities of the technical stream receive the title of bachelor in their chosen specialization.

At the upper secondary level, a school normally offers only one or two kinds of bachillerato. The national institutes of diversified middle education (Institutos Nacionales de Educación Media Diversificada or inem), frequently described as comprehensive secondary schools, are an exception since they have been designed to provide various types of academically and technically oriented bachilleratos. The escuelas normales superiores (teacher-training schools; literally “higher normal schools”) also offer secondary education with a focus on academic subjects and teacher training. Another type of institution authorized to provide secondary education is military schools (colegios militares), although the military secondary school diploma (bachiller militar or bachiller académico con orientación militar) is not common.

Successful completion of a bachillerato leads to the title of bachiller in a specific area. For example, a student graduating from the program of bachillerato académico would be awarded the title of bachiller académico. On the actual certificate, the name of the credential can be preceded by phrases like:

- título de (title of) ...
- diploma de (diploma of) ...
- grado de (degree of) ...

In fact, the above phrases can precede any Colombian academic credential, regardless of the level of study. The bachelor diploma is often referred to in English as the baccalaureate or secondary school diploma. Students graduating from international schools generally have the option of obtaining two credentials: the Colombian bachelor and its foreign equivalent or an international baccalaureate diploma.

The title of bachelor can also be acquired by passing an official validation

examination (Examen de Validación del Bachillerato Académico) administered by ICFES (Instituto Colombiano para la Evaluación de la Educación or the Colombian institute for the promotion of higher education). prior to the 1990s, the holders of a certificate of occupational aptitude (certificado de aptitud ocupacional) or CAo—formerly referred to as certificate of professional aptitude (certificado de aptitud profesional) or CAp—who accumulated two years of work experience could also obtain a certificate of equivalence of the secondary school diploma (Certificado de Equivalencia del Grado de Bachiller) issued by ICFES. Although this certificate did not have equal academic value to a regular bachelor diploma or a bachelor diploma obtained through validation, it gave its holders access to education at the intermediate and/or professional technical and technological levels. Also, although it is not a widespread practice, some upper secondary schools may allow their students to earn certain vocational designations (that is, CAos) while working toward their bachelor title. For documentation, upper secondary graduates receive a diploma, usually accompanied by a graduation record and a transcript, issued by the school where they completed their bachillerato.

The baccalaureate entitles graduates to either seek employment or apply for admission to post-secondary institutions. it is important to emphasize that all types of bachelor entitle students to enter any program at an institution of higher education, provided that they satisfy the requirements set by the institution and pass the state examination for Admission to higher education (Examen de Estado para Ingreso a la Educación Superior).

This examination is commonly referred to as examen de estado (state exam) or pruebas ICFES (ICFES SABER 11) and is held in all major cities twice a year. It has been administered directly by ICFES since 1968, but it was not until 1980 that participation in the exam became compulsory for all students planning further studies. The exam consists of a series of tests designed to assess students' competencies in the areas of natural sciences (biology, physics, chemistry), social sciences, Spanish language, philosophy, mathematics, a foreign language (English, French or German) and selected interdisciplinary topics (for example, environmental studies, culture and communication, society and violence). students can consult their scores online on the ICFES website. The results are important to schools since student performances determine the quality ranking of each educational institution.

	NUMBER OF ESTABLISHMENTS	PERCENTAGE OF ALL ESTABLISHMENTS	NUMBER OF STUDENTS ENROLLED	PERCENTAGE OF ALL STUDENTS ENROLLED
Public schools	15,723	59.3%	8,310,165	77.0%
Private schools	10,812	40.7%	2,475,304	23.0%
Total	26,535	100.0%	10,785,469	100.0%

Source: Ministerio de Educación Nacional, "Estadísticas del Sector."

* Number of public And private schools offering elementary, lower secondary And upper secondary education in Colombia (2005)

SUBJECT AREA	PRESCHOOL (TRANSITION GRADE ONLY)	ELEMENTARY (GRADES 1–5)	LOWER SECONDARY (GRADES 6–9)	UPPER SECONDARY (GRADES 10–11)
Mathematics and geometry	4			
Mathematics		6(1)* 5(2–5)	4	4
Geometry (1st semester); Statistics and probabilities (2nd semester)		2	2	2
Writing	6			
Spanish language				
Spanish		5	6(6–7) 5(8–9)	4
Orthography		0	1	1
Reading		1	0	0
Natural sciences	2	4	3	
Social sciences	2	3(1) 4(2–5)	4	1
Philosophy; Economic and political sciences				3
Specialization				3
Physics			2 (8–9)	4
Chemistry			1	4
English	8	8	8	7
Technology and computing	1	1	1	1
Artistic education				
Art	2	1	2(6–7) 1(8–9)	1
Music	2	1	0	0
Physical education, recreation and sports	2	2	2	2
Ethics and values	1	1	1	1
Religious education	1	1	1	1
Professional orientation	1	1	1	1
Extra classes	3	3	3	
TOTAL	35	40	40	40

* Sample School Curriculum with Hourly Distribution

3. Project Objectives

The followings are the major objectives of the project.

- 3.1 By reforming ICT integration in education field, it seeks to enhance the quality of the public education and contribute to resolve the educational gap among the regions for improving the Colombian national competitiveness.
 - (a) Establish and operate new innovation centers for educational information service to provide the government with complete responsibility for supporting the ICT integration in elementary and secondary schools.
 - (b) Provide collectively linked educational e-Portal service of each center to promote utilization of ICT in schools and to enhance educational

information service to the people.

- (c) Develop and provide contents needed in schools and provide in-depth and systematic ICT use training to enhance personal competency and to improve teaching methods for enhancing the quality of the education.
 - (d) Enact national guidelines for developing and distributing the contents to establish national guidelines and vitalize content industry. Furthermore, promote exchange of the educational contents among Latin American region.
- 3.2 Through enhancing cooperation between Korea and Colombia, it seeks to extend the economical relationship and establish network of people in educational fields and information & communication fields. Also it seeks to establish a foothold for oversea projects.
- 3.3 It seeks to extend educational opportunities and to contribute toward reducing the educational gap within underdeveloped countries in ICT integration in education. Thus, it seeks to achieve "Millennium Development Goals (MDGs)" and UN's "Education For All(EFA)".

4. Project Scope and Other Requirement

4.1 Project scope

The Project consists of the below-mentioned five(5) components which are closely connected:

Component 1. ICT Infrastructure

Component 2. e-Portal development & enhancement

Component 3. Content Development & Standardization

Component 4. Teacher Training

Component 5. Project Implementation Service

4.2 Other Requirement

The Ministry of Education is the Project Executing Agency (PEA) of this ICT Education Capability Building in Colombia Project.

- (a) "Integrated system of ICT in Education" Project on a turnkey basis
 - (i) Detailed design and BOQ of the technical specifications of various components of the required equipment/services are given in Technical Requirements of this document.
 - (ii) The scope of provision shall cover site survey, Analysis, designing,

supplying, installing, training, testing and commissioning of equipment and materials and related facilities on a turnkey basis.

(iii) A report shall be submitted to PEA after completion of that work.

(b) Site survey, Analysis and Designing Service

(i) As part of its “Integrated System of ICT in Education” responsibility, the successful Bidder shall be responsible to provide all services related to site survey, analysis and designing for all works of equipment/systems covered by this purchase.

(ii) All costs for materials and service shall be quoted and failure to quote shall be considered in the Bidder proposes to provide this service totally “free of charge” to PEA.

(c) Installation and Commissioning service

(i) The Bidder shall be responsible to provide all services related to installation, testing, commissioning services for all equipment/system covered by this purchase. The Bidder, in his offer, shall show details of required installation and commissioning services for NIC, 5 RICs and 50 Lab Schools related equipment and application systems.

(d) Inspection before shipment

(i) Inspection of equipment before shipment in Korea, to be termed as “Inspection before shipment”, shall be carried out for all equipment to be supplied under this purchase. The procedure for such inspection shall have to be approved by the designated person by the Purchaser before shipment.

(e) Testing

(i) Provisional Acceptance Test (PAT)

Before Provisional Acceptance of the installed system/equipment, PEA representatives shall carry out, on site, detailed tests of all equipment to ascertain their inter-working ability with relevant equipment of the other manufacturers, working reliability, concurrence to agreed technical and other specifications, inventory checking of installed equipment, etc. Such tests shall be termed as “Provisional Acceptance Test (PAT)”. Prior to the commencement of such tests, the Supplier/Contractor shall submit a proposed procedure for the PAT to be subsequently passed by PEA. The PAT will be done by a joint team of PEA Engineers and the Bidder’s Engineers.

On completion of installation and self-checking and testing of any system/equipment, the Bidder shall submit three(3) copies of self-checking and self-test results to PEA and offer that system/equipment for PAT. PEA shall start such tests within one month after receipt of the request. The Supplier/Contractor may, upon agreement by both parties, offer PAT for any part or parts of the total system. PEA may also ask the Supplier/Contractor for the partial PAT.

The Supplier/Contractor's shall be totally responsible for arrangement of all equipment, consumables, test gears and measuring equipment required for the PAT.

The Supplier/Contractor's engineer shall be liable to make necessary arrangement to complete any kinds of tests requested by PEA & PAT members during PAT procedure.

(ii) Final Acceptance Test (FAT)

After completion of the PAT, the Engineers of the Supplier will take prompt necessary steps to remedy all types of faults of equipment and replace all types of faulty equipment at the cost of the Supplier/Contractor. At the end of the "Functional Security Period for the Contract", the overall performance of all equipment will be reviewed and this review shall be termed as "Final Acceptance Test (FAT)."

The review shall include (but not limited to) the required working reliability and functional standards of the equipment to meet Bidding Documents specifications, the Bidder's responsiveness to resolve all shortcomings mentioned in PAT reports and the Bidder's removal of all pending and outstanding faults or shortages encountered during the Functional Guarantees Period for the Contract. When this FAT becomes due, the Bidder shall make an official request to PEA for starting of the FAT and PEA shall start the FAT within one month after receipt the request from the Bidder.

The Bidder shall be responsible for arrangement of all equipment, consumables, test gears and measuring equipment required (if any) for such review tests.

(iii) Operational Acceptance Tests

It is described in the GCC 27.2.

(iv) Operational Acceptance

It is described in the GCC 27.3.

(v) Partial Acceptance

It is described in the GCC 27.4.

(f) Maintenance support up to Warranty Period

- (i) The Bidder, at his own cost, shall engage at least one (1) resident management engineer for one (1) years shall be stationed in Bogota to provide full maintenance support for all equipment and sites covered by this purchase up to the end of the Warranty Period. This support service shall start from the completion date of Operational Acceptance Tests.
- (ii) The support Engineer shall be fluent in English and shall have enough knowledge of system to effectively solve all O&M problems; the engineer must also have at least three (3) years of prior experience of providing such support in other places. The Bidder shall be responsible for all types of expenditure to be borne for the manpower, including all types of transportation.
- (iii) The maintenance support service shall cover at least (but not limited to) the following services;
 - Regular visits to all relevant sites to check and monitor different aspects of the working system.
 - To remain stand-by to respond in the shortest possible time during any call by PEA.
 - Helping PEA personnel to solve different software and hardware problems related to proper O&M of the equipment.
 - Identify and remove different bugs in the system's operational software.

(g) Certificate to be issued

(i) Provisional Acceptance Certificate (PAC)

Upon successful completion of the PAT for any, or all equipment covered by this purchase, the relevant authority of PEA, shall issue a "Provisional Acceptance Certificate (PAC)" for the ICT system/equipment concerned. The exact breakdown of the purchase into various PAC components and the number of PACs to be issued shall be agreed upon between PEA and the Bidder during contract negotiation.

(ii) Final Acceptance Certificate (FAC)

After completion of the FAT, if and only if, no outstanding issue has been detected, “Final Acceptance Certificate (FAC)” shall be issued by the relevant authority of PEA.

(iii) Certificate of Commencement of Work (CCW)

On commencement of the project work and on receipt of written request from the Bidder, the Project Office of PEA will issue CCW.

(iv) Successful Completion of Services’ Certificate (SCSC)

During implementation period of the Integrated System of ICT in Education Project, the Bidder shall provide various services, training, and maintenance assistance service. On completion of such service components and on receipt of written request from the Bidder, the Project office of PEA shall issue “Successful Completion of Services’ Certificate (SCSC)” for each of such service components. The exact breakdown of the purchase into various SCSC components and the number of SCSCs to be issued shall be agreed upon between PEA and the Bidder during contract negotiation.

(v) Arrival of Goods and Materials Certificate

During implementation period of the Integrated System of ICT in Education Project, the Bidder shall ship various consignments of foreign goods and materials and shall also supply items from local market. On arrival of such consignments to PEA sites or PEA stores (whichever is applicable) and on receipt of written request from the Bidder, the relevant office of PEA shall issue “Arrival of Goods and Materials Certificate” for each of such consignments. The number of such consignments shall be decided by the Bidder in accordance with its approved implementation plan.

(vi) Progress Certificate

During implementation period of the Integrated System of ICT in Education Contract, the Supplier/Contractor shall submit “Quarterly Progress Report” After receipt of such report, the Project office of the Ministry of Education of Colombia shall issue a “Quarterly Progress Certificate” to the Supplier/Contractor.

(vii) Certificate for completion of Training service

During implementation period of the Integrated System of ICT in Education Project, the Supplier/Contractor shall provide Training Services. After the completion of such Training Services, the relevant office of PEA shall issue a “Certificate for completion of Training Service” to the Supplier/Contractor.

(viii) Certificate for clearance of Obligations

After the end of Performance Guarantee period, the Supplier/Contractor shall give a written undertaking to the Procurement Office of PEA to the effect that, in relation to the Integrated System of ICT in Education Project execution of the Contract, it has no outstanding dues, liabilities and obligations towards any organization inside Colombia. After receipt of such undertaking and ascertaining the same by proper verification, the relevant office of PEA shall issue a “Certificate for Clearance of Obligations” to the Supplier/Contractor. Such a certificate shall be issued only if no such dues, liabilities and obligations are detected.

(ix) Quotation for additional equipment

If the Bidder thinks that any additional system/equipment, not listed in this document, is needed for proper implementation and subsequent O&M of the proposed system/equipment, he shall quote for such system/equipment. If any such system/equipment is not quoted, it shall be deemed that no additional system/equipment is necessary for proper implementation and subsequent O&M of the proposed system/equipment. If during implementation and subsequent O&M up to performance guarantee period, either the Bidder or the Purchaser finds that any additional system/equipment are obligatory for proper implementation and subsequent O&M of the system/equipment, the Bidder shall be liable to supply such systems or equipment, whatever be the required quantity.

(x) Omission of any Mandatory Items in the Contract BOQ

The Bidder shall note that, even if any or many work(s), equipment or service(s) mentioned in this document as mandatory, is not mentioned in the Contract BOQ for any reason, the Bidder shall not be automatically relieved of his responsibility for those items. But if such omission(s) has (have) previously been agreed, in writing, by PEA, the Bidder shall not be made liable for such omitted items. Such approved omissions, if any, shall have to be put either into the Contract

document or into any other document which subsequently is declared as part of the Contract.

(xi) Prevalence of different clauses and Sections

If, for any item, the contents of a Clause of any Section contradict with the contents of any other Clause of the same or other Section of the Bidding Documents, the prevalence of the Clause shall be as follows:

- In case of different Section, later Section shall supersede previous Section.
 - In case of same Section, later Clause shall supersede previous Clause.
 - In case of later corrections by PEA, corrections shall prevail with its due position.
-

B. BUSINESS FUNCTION AND PERFORMANCE REQUIREMENTS

1. General Requirements to Be Met by the System

The ultimate requirements of the Project include:

- (a) Establishment of unified educational information environment in primary and secondary education, which will provide:
 - Access to high quality national and local educational e-learning materials, including the Project deliverables; 33 courseware for 3 subjects and for all 11 public education grades
 - Access to test knowledge and conduct examinations and evaluations of education quality with the use of program applications throughout the country;
 - Methodological support and means for continuous professional development of teachers;
 - Development of open education approach on the basis of interactive distance learning techniques;
 - Step by step transformation of education based on ICT;
- (b) Increasing the number of ICT teachers;
- (c) Improvement of training of ICT teachers and specialists;
- (d) Improvement of quality of education

For the successful implementation of the Project, the Purchaser shall have the following responsibilities:

- (a) Connection of Lab Schools to Internet (DSL or Fiber-optic);
- (b) Classrooms Technical Preparation (CTP) for Lab Schools;
- (c) NIC & RICs Space Acquisition and related construction;
- (d) NIC & RICs Operational expenditures;
- (e) Other responsibilities that may be needed in the implementation of the Project;

2. Acronyms Used in These Technical Requirements

Terminology	Explanation
A/D	Analog/Digital
A/V	Audio Visual
AAC	Advanced Audio Coding
AC	Alternating Current
AID	Automatic Consistent Isolate Durable
ACU	Access Control Unit
ADF	Automatic Document Feeder
ADSL	Asymmetric Digital Subscriber Line
AES/EBU	Audio Engineering Society/European Broadcasting Union
AICC	Aviation Industry CBT Committee
AIFF	Audio Interchange File Format
ANSI	American National Standards Institute
AP	Access Point
AVC	Advanced Video Coding
AVI	Audio Video Interleave, a multimedia container format and file type
AVR	Auto Voltage Regulation
B/W	Black and White
BMP	File frame extension for the Bitmap image file format
BTU	British Thermal Unit
CBT	Computer-Based Training
CCD	Charge Coupled Device
CD	Compact Disk
CDR	Content Development Research office (of RIC)

cd/m ²	Candela per square meter
Terminology	Explanation
CF Memory	Compact Flash Memory
CIF	Common Intermediate Format
CIP	Carriage and Insurance Paid
CMDB	Configuration Management Database
CMOS	Complementary Metal Oxide Semiconductor
CMS	Contents Management System
CPU	Central Processing Unit
CTP	Classroom Technical Preparation
DAS	Direct Attached Storage
DBMS	Database Management System
DC	Direct Current
DDR	Double Data Rate
DHCP	Dynamic Host Configuration Protocol
DLP	Digital Light Processing
DNS	Domain Name System
dpi	dots per inch
D-Sub	D-subminiature, A common type of electrical connector
DSP	Digital Signal Processing
DV	Digital Video
DVD	Digital Video (Versatile) Disk
DVI	Digital Visual Interface, a video interface for digital displays
DVR	Digital Video Recorder
ea	each
EJ	Enterprise JavaBeans

Email	Electronic mail
EM Lock	Electric Magnetic Lock
Terminology	Explanation
EOT	End-of-tape, a term in magnetic tape data storage
e-Portal	Educational Portal
EQ	Equalizer
EXR	A High Dynamic Range image file format standardized by Industrial Light and Magic
FB-DIMMs	Fully Buffered-Dual Inline Memory Module
F4V	ISO base media file format
FIFO	First In, First Out
FLV	Flash Video
FM	Frequency Modulation
FSB	Front Side Bus
FTP	File Transfer Protocol
FTPS	File Transfer Protocol Structure
Full D1	SMPTE digital recording video standard
GB	Giga Byte
GBIC	Gigabit Interface Converter
Gbps	Giga Bits per second
GDDR	Graphic Double Data Rate
GHz	Giga Hertz
GNU	Unix-like computer operating system
GUI	Graphical User Interface
H.263	H.263 is a video compression standard
H.264	H.264/MPEG-4 Part 10 or AVC (Advanced Video Coding)
H/W	Hardware
HBA	Host Bus Adapter

HD	High Definition
HDD	Hard Disk Driver
Terminology	Explanation
HDMI	High Definition Multimedia Interface
HDV	High Definition Video
HF/LF	High Frequency/Low Frequency
HIV	High Heat-Resistant PVC Insulated Wire
HTTP	Hypertext Transfer Protocol
HTTPS	Hypertext Transfer Protocol over Secure Socket Layer
Hz	Hertz (cycles per second)
I/O	Input and Output
ICM	Internet Control Message Protocol
ICT	Information & Communication Technology
ID	Identification
IEC	International Engineering consortium
IEEE	Institute of Electrical and Electronics Engineers
IMS QTI	IMS Question and Test Interoperability specification
IOS	Intelligent Office System
IPR	Intellectual Property Rights
IPS	Intrusion Prevention System
ISA Server	Microsoft Internet Security and Acceleration Server
ISO	International Organization for Standardization
ISP	Internet Service Provider
ISSA	ICT Skills Standards for All
ISSS	ICT Skills Standards for Students
ISST	ICT Skills Standards for Teachers
ITU-T	International Telecommunication Standardization Sector
J2EE	Java 2 Enterprise Edition

JAXB	Java And XML Binding
JAX-WS	Java API for XML Web Service
Terminology	Explanation
JMX	Java Management Extensions
JPEG	Joint Photographic Experts Group
JSF	Java Specification Requests
JSR	Java Specification Requests
K – 12	Kindergarten to Grade 12
KB	Kilo Byte
KHz	Kilo Hertz
KPI	Key Performance Indicator
KVA	Kilo Volt Ampere
KVM	A hardware device that allows a user to control multiple computers from a single keyboard, video monitor and mouse.
Kw	Kilowatt
L/R	Left/Right
LAMS	Learning Activity Management System
LAN	Local Area Network
LCD	Liquid Crystal Display
LDAP	Lightweight Directory Access Protocol
LED	Light-Emitting Diode
LMS	Learning Management System
LPI	Line per Inch
LO	Learning Object
LOM	Learning Object Metadata
LT	Leader Teacher
LTO	Linear Tape-Open
LVD/SE	Low Voltage Differential/Single Ended

MAC Address	Media Access Control address
MB	Mega Byte
Terminology	Explanation
Mbps	Mega Bits per second
MCU	Main Control Unit
MJPEG	Motion JPEG
MKV	Filename extension for the Matroska video format
MOE	Ministry of Education of Colombia
METS	Metadata Encoding and Transmission Standard
MHz	Mega Hertz
MIB	Management Information Base
mm	millimeter
MOV	Filename extension for the QuickTime multimedia file format
MP3	MPEG-1 Audio Layer 3, Digital Audio Encoding Format
MPEG	Moving Picture Experts Group
MRTG	Multi Router Traffic Grapher
MS	Microsoft
MT	Master Teacher
MXF	Material eXchange Format
mW	milli Watt
NAS	Network Attached Storage
NIC	Network Interface Card
NIC	National Innovation Center
NTP	Network Time Protocol
NTSC	National Television System Committee
O/S	Operating System
OAI-PMH	Open Archives Initiative Protocol for Metadata Harvesting

ODD	Optical Disk Drive
OID	Object Identifier
Terminology	Explanation
OLAP	OnLine Analytical Processing
OS	Operating System
OSD	On Screen Display
PABX	Private Automatic Branch Exchange
PAL	Phase Alternating Line
PCI	Peripheral Component Interconnect
PDU	Power Distribution Unit
PIP	Picture In Picture
PLL	Phase Locked Loop
PNG	Portable Network Graphics
POSIX	Portable Operating System Interface
PPM	Page Per Minute
PSD	File format of Adobe System's Photoshop program
PSTN	Public Switched Telephone Network
PTZ	Pan / Tilt / Zoom
RAID	Redundant Array of Inexpensive Disks
RAW	A variety of image files used by digital cameras containing the unprocessed data from the sensor
RCA	A type of electrical connector that is commonly used in the audio/video equipment.
RENATA	Red Nacional Académica de Tecnología Avanzada
REST	Representational State Transfer
RFID	Radio-Frequency Identification
RGB	Red, Green, Blue. Analog component video standards (e.g., RGBS, RGBHV, RG&SB)
RIC	Regional Innovation Center

RJ	Registered Jack
RFC	Request For Comments
Terminology	Explanation
rpm	Revolutions per Minute. It is most commonly used as a measure of rotational speed of some mechanical component.
RSS	Really Simple Syndication
RTMP	Real Time Messaging Protocol
RTMPE	Encrypted RTMP
RTMPS	RTMP Secure
RTMPT	RTMP Tunneled
RTMPTE	Encrypted RTMPT
RTSP	Real Time Streaming Protocol
RTP	Real-time Transport Protocol
RUS/LAT	Russian/Latin
S/N	Signal to Noise Ratio
S/W	Software
SAN	Storage Area Network
SAS	Serial Attached SCSI
S-ATA	Serial Advanced Technology Attachment
SCF	Specialized Computer Furniture
SCORM	Sharable Content Object Reference Model
SCP	Session Control Protocol
SCSI	Small Computer System Interface
SD	Standard Definition
SDI	Serial Digital Interface
SDRAM	Synchronous Dynamic Random Access Memory
SDTI	Serial Data Transport Interface, A way of transmitting data packets over a Serial Digital Interface data stream

SFP	The small form-factor pluggable (SFP) is a compact, hot-pluggable optical transceiver used in optical communications.
Terminology	Explanation
SFTP	SSH File Transfer Protocol
SLR	Single Lens Reflex
SMB	System Management Bus, a PC communication bus
SMPTE	Society of Motion Picture and Television Engineers
SNMP	Simple Network Management Protocol
SNS	Social Network Service
SQL	Structure Query Language
SSH	Secure Shell
SSL	Secure Sockets Layer
STAD	Student Team Achievement Division
SWORD	Simple Web-service Offering Repository Deposit
SXGA	Super eXtended Graphics Array(1280 X 1024 pixels)
SXGA+	Super eXtended Graphics Array Plus(1400 X 1050 pixels)
TB	Tera Byte
TCP/IP	Transmission Control Protocol / Internet Protocol
TGA	True vision Graphics Adapter
TIF	Tagged Image File Format
UNESCO	United Nation's Educational, Scientific and Culture Organization
UoL	Unit of Learning
UPS	Uninterruptible Power Supply
URL	Uniform Resource Locator
USA	United States of America
USB	Universal Serial Bus

UTF-8	UCS Transformation Format - 8-bit
VoD	Video on Demand
WAS	Web Application Server
Terminology	Explanation
WAV	Waveform Audio File Format
WBT	Web-Based Training
WebDAV	Web Distributed Authoring and Versioning
WebM	Audio-video format designed to provide royalty-free, open video compression for use with HTML5 video
WiFi	Wireless Fidelity
WMV	Windows Media Video
WSRP	Web Server for Remote Portlets
WYSIWYG	What You See Is What You Get
XGA	Extended Graphics Array(1024 X 768 Pixels)
XHTML	eXtensible HyperText Markup Language
XLR	Electrical connector commonly used in audio equipment.
XML	eXtensible Markup Language
years	years

C. TECHNICAL SPECIFICATIONS

1 Overall Requirements

1.1 General Technical Requirements

(a) Electrical Power

All active (powered) equipment must operate on 110 Volts at 60 Hertz. All active equipment must include power plugs standard in the Republic of Colombia.

(b) Environmental

Unless otherwise specified, all equipment must operate in environments of general condition of the Republic of Colombia: 5 ~ 40 degrees centigrade, 20-90 percent relative humidity, and 0-10 grams per cubic meter of dust.

(c) Safety

All electronic equipment that emits electromagnetic energy must be certified as meeting international standards.

(d) Regulations and legislations

The Bidder shall comply with all laws and regulations of the Republic of Colombia from the bidding stage to the whole period of implementation and maintenance.

1.2 General Functional Requirements

(a) The Supplier shall develop for acceptance by the Purchaser an implementation plan to develop the Deliverables specified above that best serves the Purchaser's objectives. The methodology to be adopted for the Component shall be clearly stated in a proposed plan.

(b) The Bidder shall propose a plan to enhance the awareness of educational information and/or e-learning in general for the stakeholders of Colombia.

2. ICT Infrastructure

2.1 Objective of the Component

The ICT Infrastructure component has the following objectives;

- (a) To introduce new H/W and S/W to enhance the service capability of Colombia Aprende.
- (b) To establish a NIC Operation Office to take responsibility in operating Colombia Aprende and to manage 5 RICs established in 5 different regions.
- (c) To provide equipment to 5 RICs to enhance content development capacity.
- (d) To provide equipment to 5 RICs to enhance teacher training capacity.

2.2 Conceptual design of the Component

- (a) Overall Configuration of NIC & RICs

To accomplish the objectives of the Project, this component is designed to establish 1 NIC and 5 RICs with equipment either as an addition or as new establishment of 50 Lab Schools are also to be included in this component to be supplied with latest technology and new hardware.

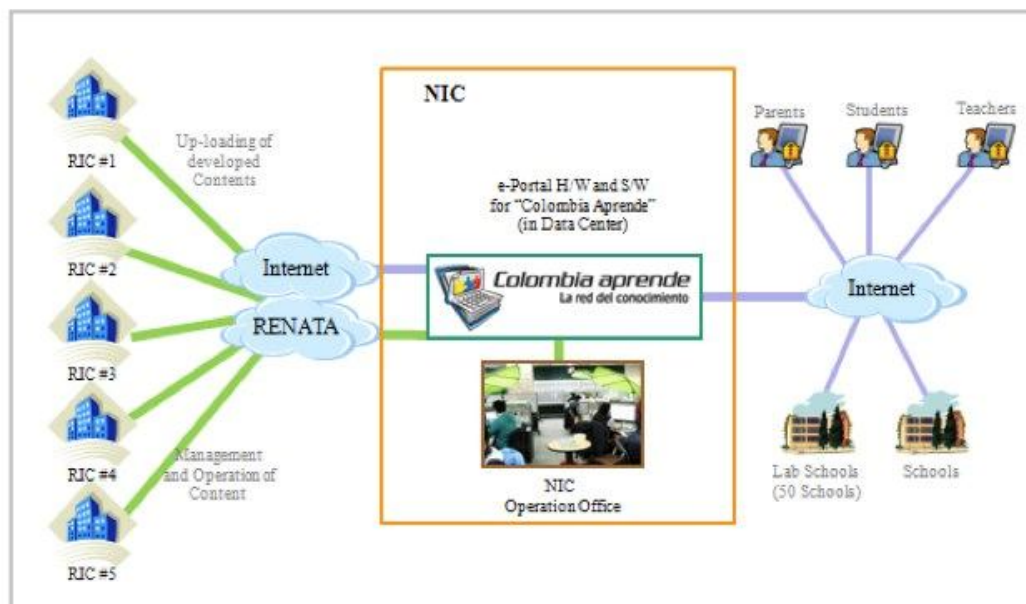

- (b) NIC Configuration

NIC is to be established including “e-Portal H/W and S/W” to strengthen the capability of Colombia Aprende with the function to supervise/manage the overall operation in NIC and 5 RICs. The e-Portal H/W and S/W are to be dealt at Section 3.

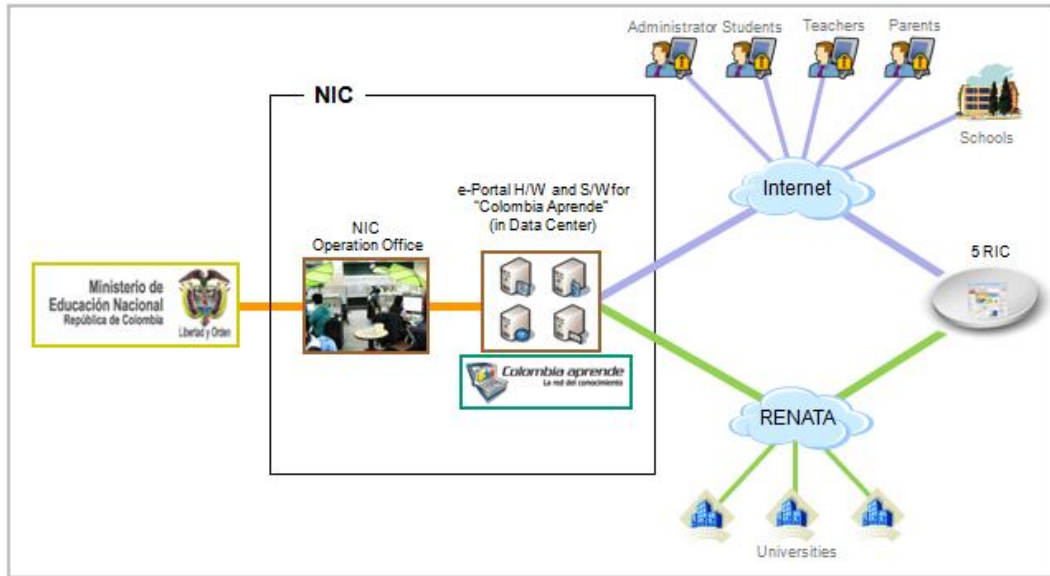

(i) NIC Operation office

NIC Operation Office is the main control tower for the operation of NIC. It includes the supply, delivery and installation of H/W & S/W and office interior design of 1 room.

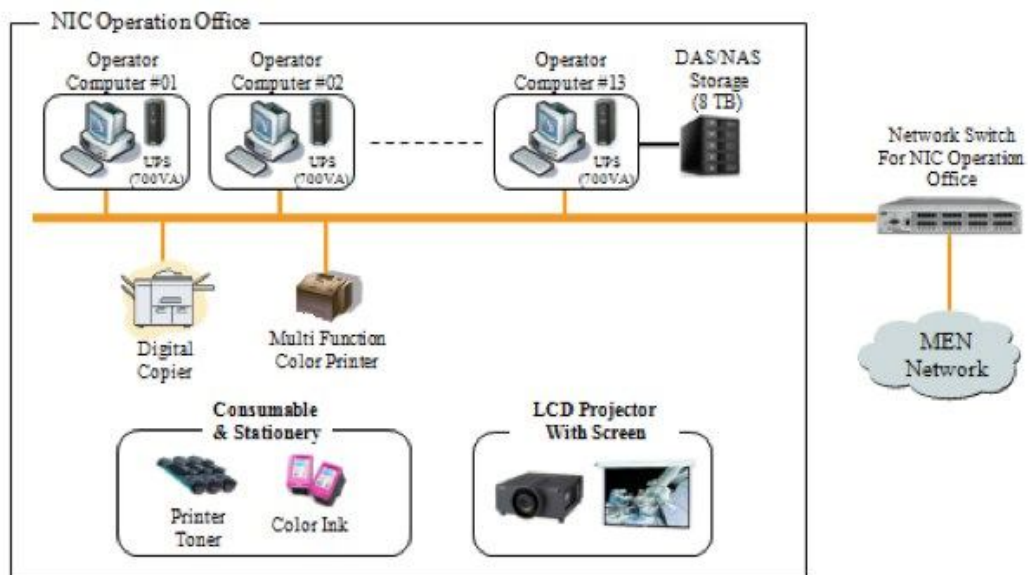

(c) RIC Configuration

RIC is to be established in 5 regions (including central region) in Colombia. RIC is to be operated by an institution or organization in each region.

RIC consists of 1 set of Server and Storage System, 1 RIC Operation Office, 1 Multimedia Studio, 1 Content Development and Research Office, 1 Supporting Office, 2 Multimedia Classrooms and 2 General Classrooms.

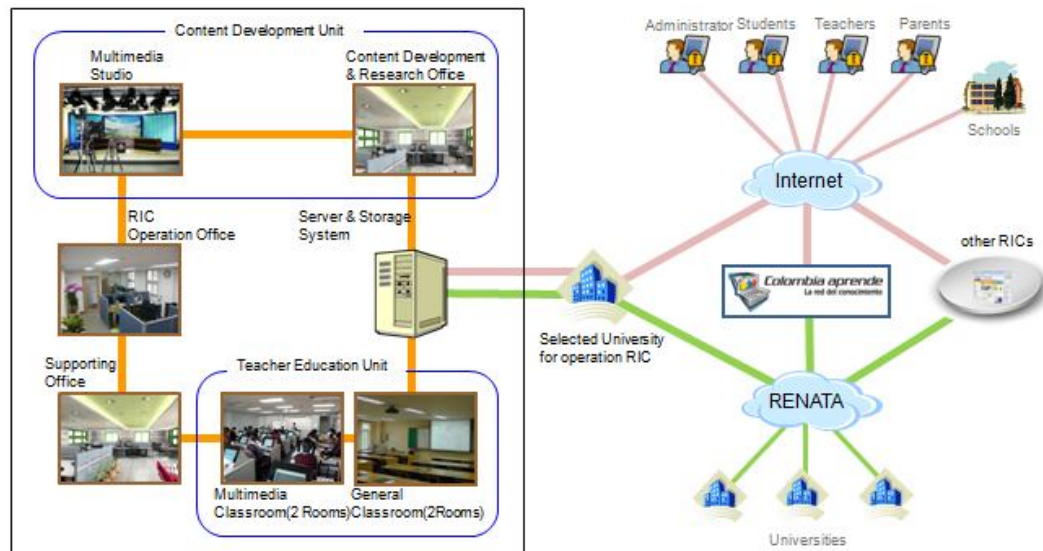

(i) Server and Storage System

The Server and Storage System for each RIC includes 1 test server for uploading the content developed by each RIC, 1 digital resource management server with 1 DAS storage to store and manage the original source files, and 7 workgroup switches.

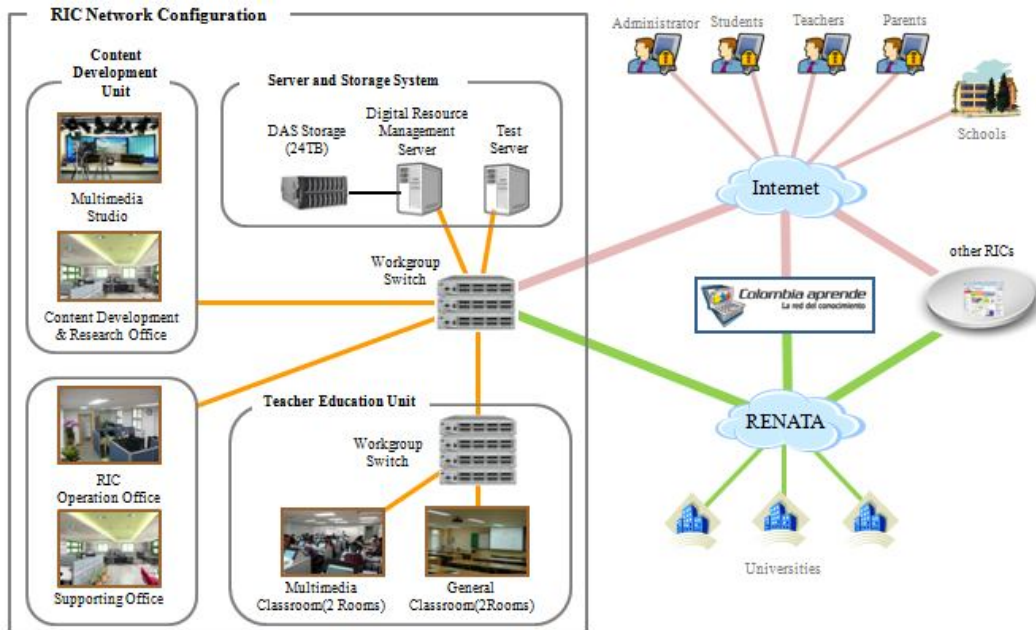

(ii) RIC Operation Office

RIC Operation Office manages the overall operation of RIC as well as the provided H/W and S/W. It includes computers, OA equipment, projector & screen as well as interior design with furniture and an air conditioner for 7 staff.

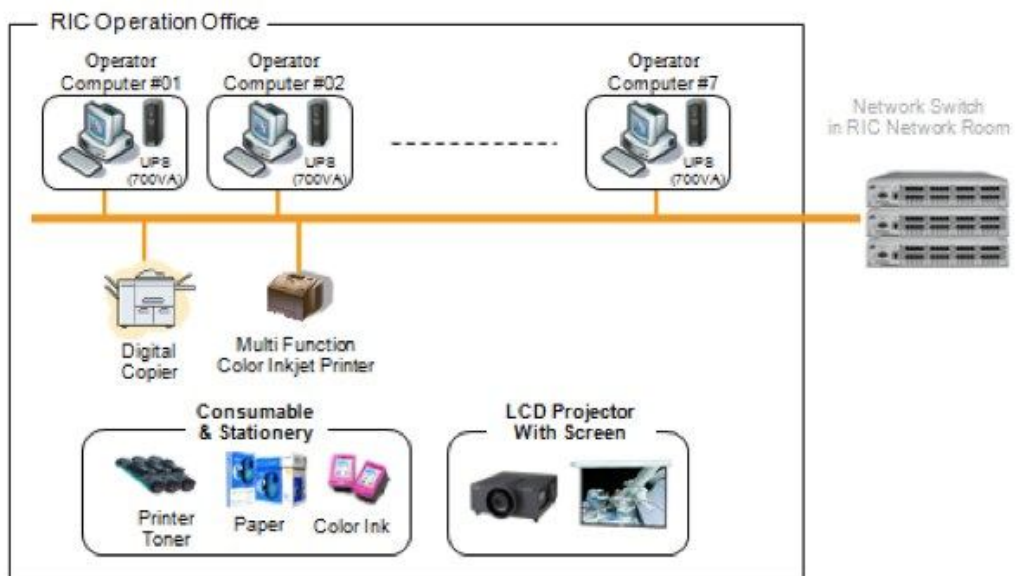

(iii) Multimedia Studio

Multimedia studio includes cameras to create high quality video content, production system and editing system such as switcher,

content storage, special lighting system, and soundproof construction.

Multimedia studio is to be established with the full HD production system. Camera system includes optional items for outdoor shooting as well as studio shooting. 1 DAS storage is to store the original data as well as the edited content to share with CDR staff.

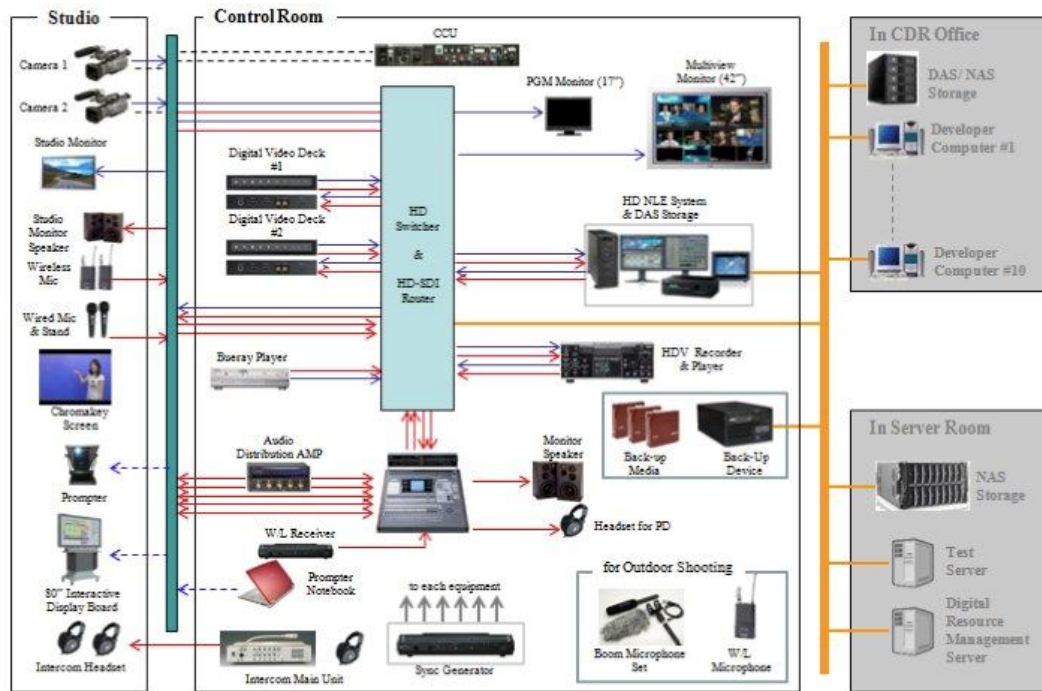

(iv) Content Development and Research (CDR) office

Content Development and Research Office is to develop the educational content. CDR is to accommodate 10 content developers. Hardware to be provided includes 10 PCs, OA equipment, projector, camera, camcorder and others. In addition, authoring S/W and office program to make the contents are to be included.

One of the important functions of Content Development and Research Office is the distribution of the developed content. The content is to be distributed on-line via the newly established e-Portal.

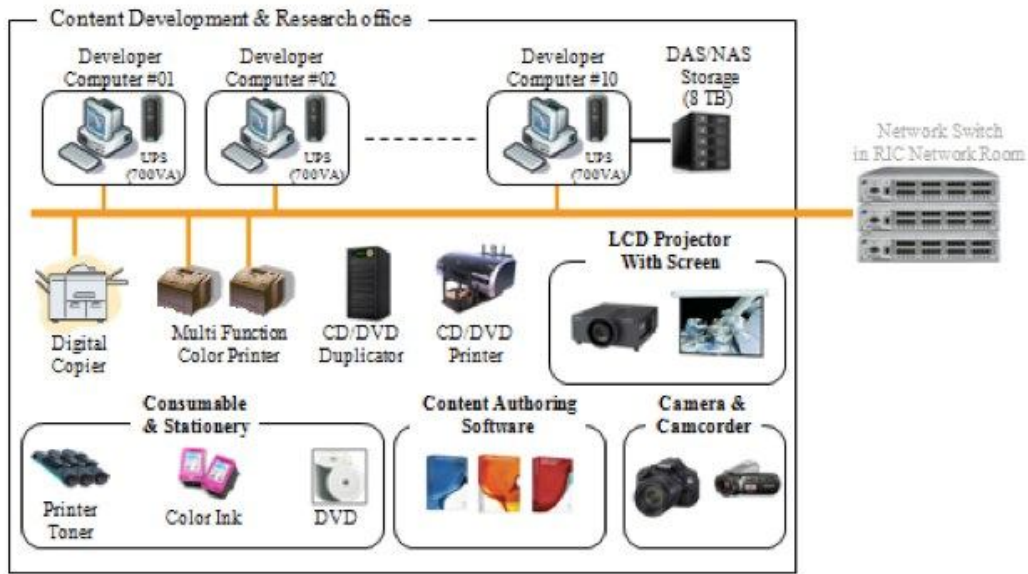

(v) Supporting Office(Central RIC)

Supporting office for the Central RIC is to accommodate master teachers and content developers.

8 notebook computers for master teachers and 19 PCs for content developers will be allocated to the supporting office.

In addition, authoring S/W for Content Developer and office program to make the contents are to be included.

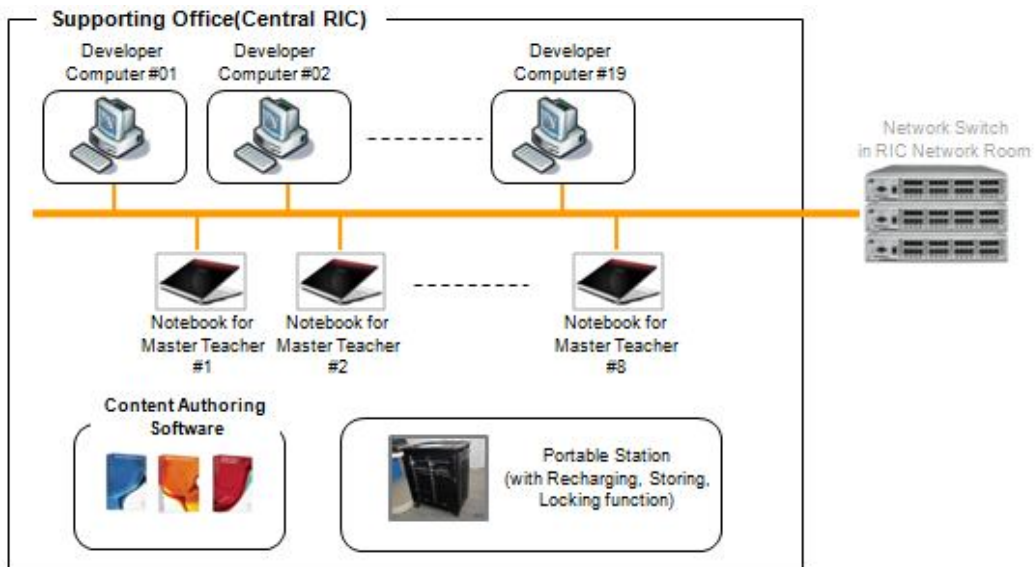

(vi) Supporting Office(Other 4 RIC)

Supporting office for other RIC (4 RIC) is for master teachers and

content developers.

8 notebook computers for master teachers and 14 PCs for content developers will be allocated to the supporting office for each RIC.

In addition, authoring S/W for Content Developer and office program to make the contents are to be included.

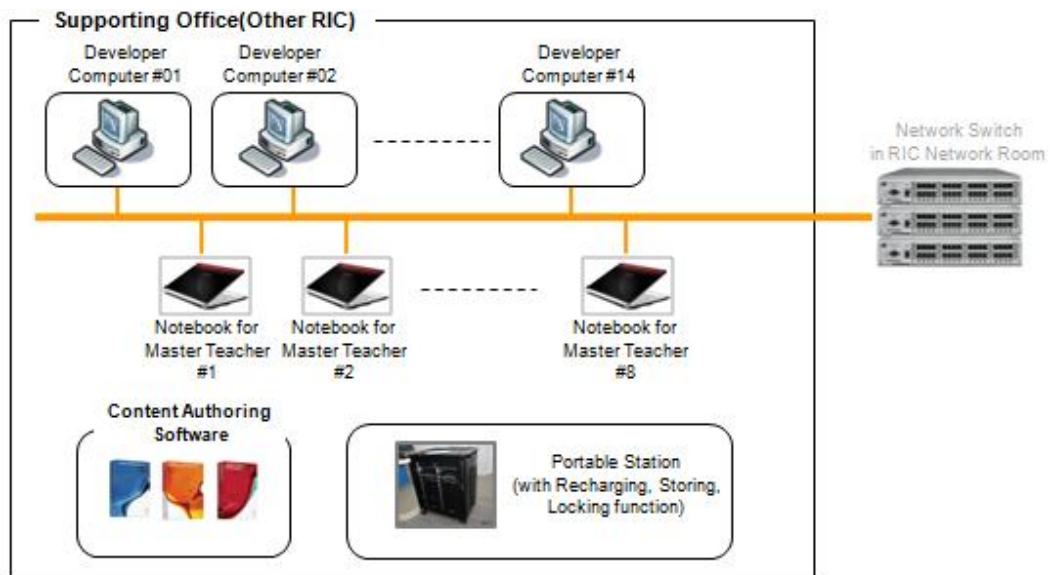

(vii) Multimedia Classroom Type A

Multimedia Classroom Type A is to accommodate 30 trainees and 1 trainer for teacher training.

The Central RIC is designated as the Teacher Training Center to train Master Teachers.

Multimedia Classroom Type A for RIC is to be furnished with 30 PCs for trainees and 1 PC for a trainer. In addition, video conferencing system, audio/visual system, e-podium and OA equipment is to be established. It is to be provided with interior, furniture and Air Conditioner.

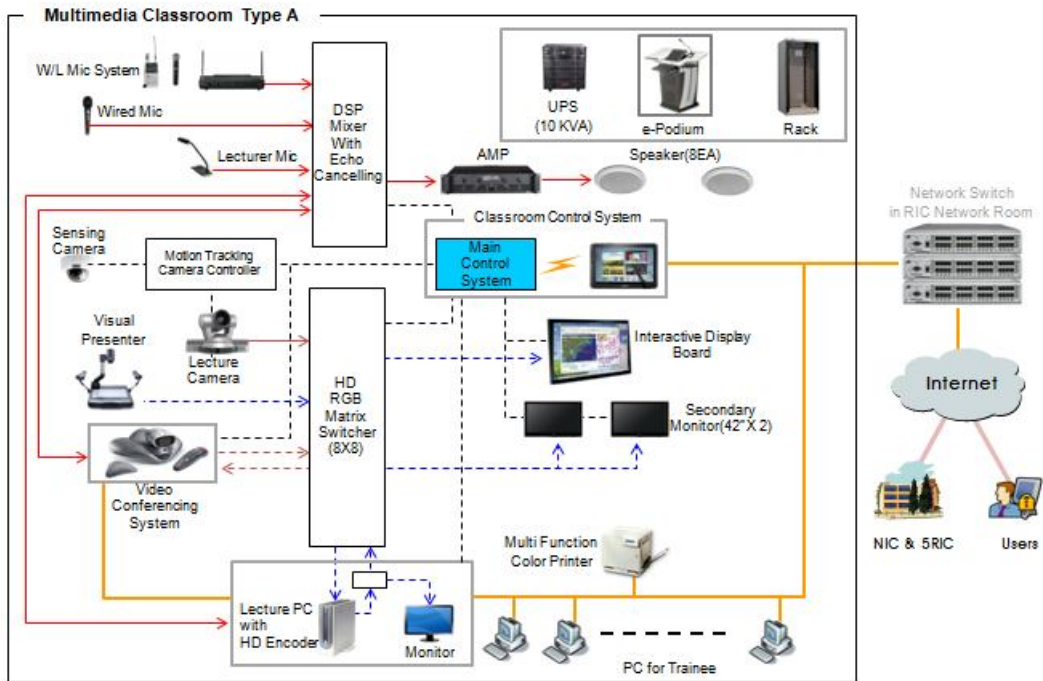

(viii) Multimedia Classroom Type B

Multimedia Classroom Type B is to accommodate 30 trainees and 1 trainer for teacher training.

Multimedia Classroom Type B for RIC is to be furnished with 30 PCs for trainees and 1 PC for a trainer. In addition, audio/visual system, e-podium and OA equipment is to be established. It is to be provided with interior, furniture and Air Conditioner.

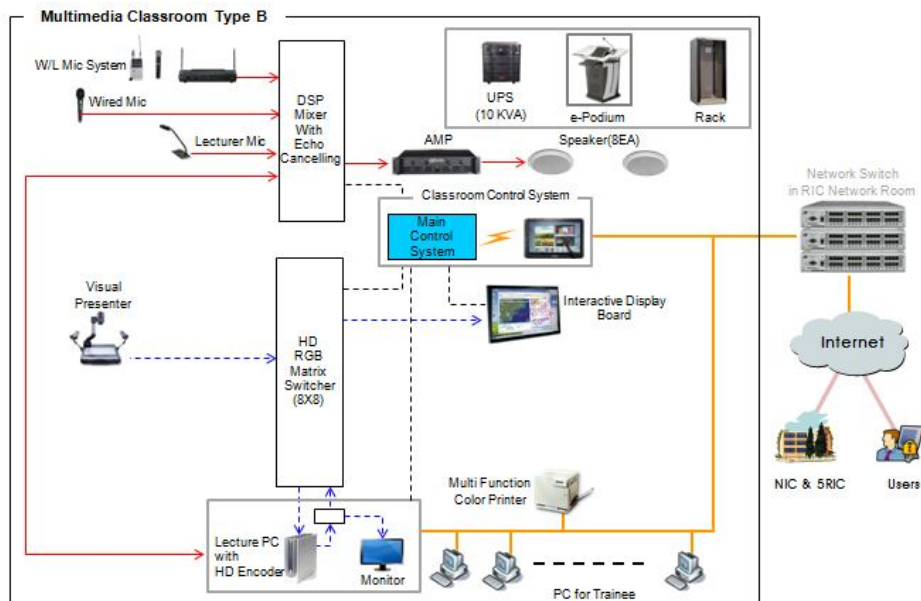

(ix) General Classroom

Classroom is to accommodate 30 trainees and 1 trainer for teacher training. However, it is to be furnished with 15 PCs for trainees and 1 PC for a trainer. 2 trainees are to share 1 PC for a group project.

In addition, it is to be furnished with audio/visual system, e-podium, OA equipment as well as MS office program and content authoring S/W. It is to be provided with interior, furniture and Air Conditioner.

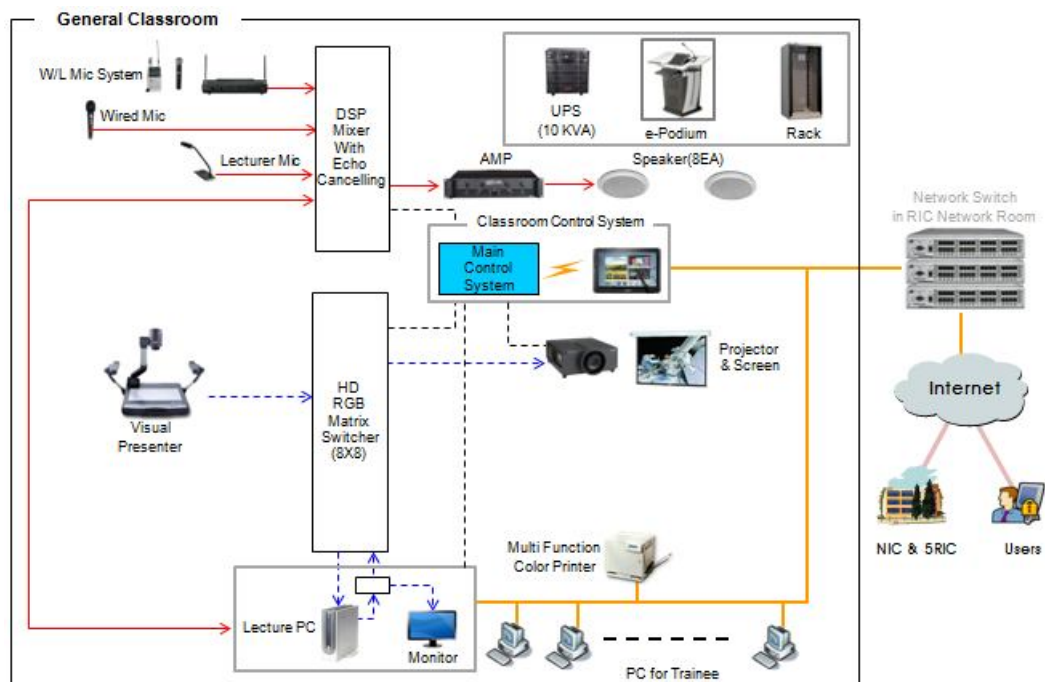

(x) RIC Security System

RIC Security System is to be installed for each RIC to protect the equipment and control access to RIC facilities. 10 cameras, 1 set of DVR, 18 motion detection sensors are to be installed at each RIC.

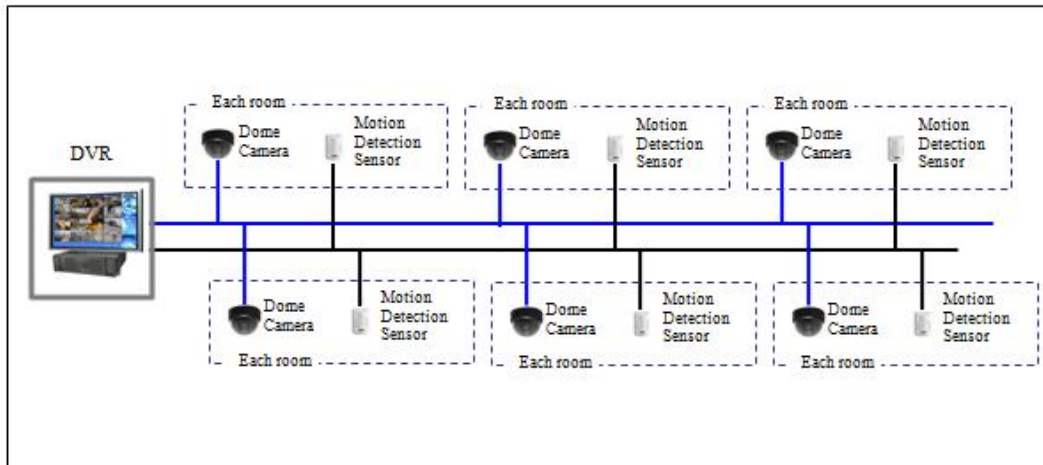

(d) Lab School(Pilot School)

Computers and software are to be provided for Lab Schools to be used in the class to evaluate the quality of the teachers who have received the Teacher training and of the content developed by RIC.

The wireless network environment is to be established for Lab Schools so that mobile equipment can be utilized through designated places of the schools.

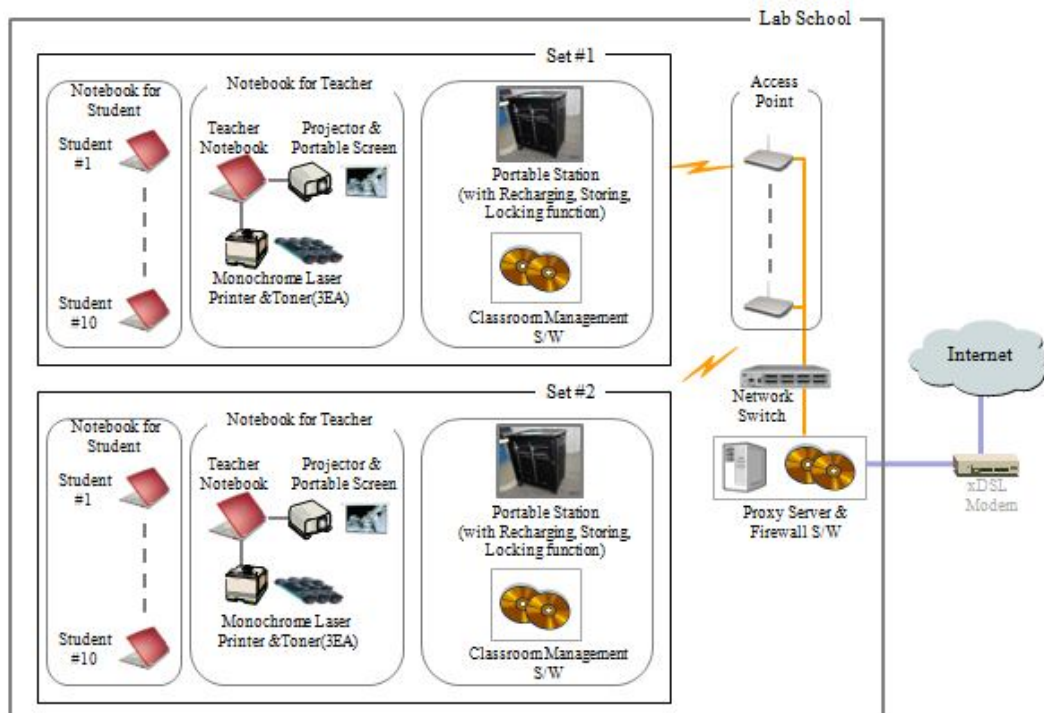

2.3 Project Sites

ICT Infrastructure is to be established in 1 NIC, 5 RICs and 50 Lab Schools

(a) NIC

NIC is to be established in the following 2 locations;

- (i) Internet Data Center for e-Portal H/W
 - In or near Bogota (Within a driving range)
- (ii) NIC Operation Office
 - Inside the Ministry of Education of Colombia

(b) RICs

RICs are to be established in the following 5 locations;

- (i) Alianza CIER Centro (Central RIC) – Bogota
- (ii) Alianza Oriente - Villavicencio
- (iii) Alianza Innovatic - Medellin
- (iv) Alianza Sur Occidente - Cali
- (v) Alianza CIER Norte– Cartagena



* Refer to the Attachment 6 RIC Alliance List. Addresses are to be given on a bid notice.

(c) Lab Schools(Pilot Schools)

Total of 50 Lab Schools, 10 from each RIC, are to be selected and provided with equipment. Lab Schools of each RIC shall be provided with minimum 2Mbps Internet connection (Satellite connection excluded).

Information regarding the selected schools is to be furnished upon commencement of the Project.

2.4 **Deliverables:** The following deliverables are the minimum quantities and technical specifications required for all bidders. In case these minimum quantities and technical specifications are not satisfied, it will be considered non-responsive of a subcomponent and zero point will be given for the sub-component where the understated mandatory requirements are not met (for example, unsatisfied e-Portal server -> zero point for NIC e-Portal Hardware). The bidder shall provide adequate supporting information that the deliverables proposed by the bidder is fully compliant with the requirements. Insufficient or incomplete information and any omission of supporting information may result in non-responsive of a subcomponent. The Bidder shall provide all the information to prove that the proposed deliverables meet the technical specifications specified below. The detailed specification on the attachments the Purchaser has provided separately include the requirements below and the other requirements that are also required and will be evaluated but will not be considered non-responsive even if some of the requirements not mentioned as the mandatory requirements specified below are not met. However, the bidder shall acknowledge that the compliance rate of the deliverables will have a great effect on the technical evaluation. In addition, the Successful Bidder shall remedy all the unsatisfied requirements for signing the contract with the Purchaser. In case of failure of remedying all the unsatisfied requirements, its bid shall be rejected and the Purchaser shall continue the negotiation with the next lowest evaluated Bidder.

Fulfillment of minimum technical specifications shall be explicitly stated on both the proposal and supporting documents. Any omission or insufficient/vague/improper statement of the minimum technical specifications on the proposal may result in either deduction of points or no point for that particular sub component (type of processor, model number and other details shall be specified).

In addition, all pages in the proposal, including the brochures and annex, must be numbered, both on original and copies. These deliverables must be presented in a table that has the following elements: Requirement, Proposal, Page number(s) for the brochure(s), Requirements not fulfilled, and Added Value.

(a) NIC Configuration

No	Classification	Specification	Unit	Q'ty
1	e-Portal Hardware	Hard ware & Soft ware	Set	1
2	NIC Operation	H/W and S/W	Set	1

	Office	Interior	Set	1
--	--------	----------	-----	---

(i) e-Portal Hardware

Refer to the Section 3.

(ii) NIC Operation Office

(aa) H/W & S/W

No	Equipment	Specification	Unit	Q'ty
1	Operator Computer	<ul style="list-style-type: none"> • Processor: Intel core i5-2400 processor (3.10 GHZ,6MB) or above • Memory: 6GB • HDD: 1TB • Monitor: 22" LCD Monitor 	Set	13
2	Digital Copier	Color Print, Copy, Scan, Fax <ul style="list-style-type: none"> • Print Speed (Black): Up to 25 ppm • Print Speed (Color): Up to 25 ppm • Interface: USB 2.0, Ethernet 10/100/1000 Base TX 	Set	1
3	Multi Function Color Printer	Color Print, Copy, Scan, Fax <ul style="list-style-type: none"> • Print Speed (Black): 21ppm • Print Speed (Color): 21ppm • Interface: USB 2.0, Ethernet 10/100 Base TX 	Set	1
4	UPS for PC	<ul style="list-style-type: none"> • Output Capacity: 450Watts / 750 VA 	Set	13
5	Video Projector & Screen	<ul style="list-style-type: none"> • Native Resolution: XGA (1024x768) • Brightness (ANSI-Lumens): 4000ANSI Including 120" Screen	Set	1
6	DAS/NAS Storage for RIC content backup	<ul style="list-style-type: none"> • HDD: 8TB • Network: 2 Gigabit Ethernet 	Set	1
7	Consumables &	Toner for Multifunction Color	EA	5

	Stationery	Printer (Black, Minimum Printing Capacity : 2,000pages)		
		Toner for Multifunction Color Printer (Yellow, Minimum Printing Capacity : 2,000pages)	EA	5
		Toner for Multifunction Color Printer (Magenta, Minimum Printing Capacity : 2,000pages)	EA	5
		Toner for Multifunction Color Printer (Cyan, Minimum Printing Capacity : 2,000pages)	EA	5
		Toner for Digital Copier (Black, Minimum Printing Capacity : 2,000pages)	EA	3
		Toner for Digital Copier (Yellow, Minimum Printing Capacity : 2,000pages)	EA	3
		Toner for Digital Copier (Magenta, Minimum Printing Capacity : 2,000pages)	EA	3
		Toner for Digital Copier (Cyan, Minimum Printing Capacity : 2,000pages)	EA	3
8	Software	<i>MS-Office, Home and Business or above (latest)</i>	Set	13
9	Workgroup Switch	<ul style="list-style-type: none"> • <i>1G Fiber Ethernet: 4ports or more</i> • <i>10/100/1000 Mbps Ethernet: 24ports or more</i> 	Set	1
10	Power & Network Cabling	Network Cabling and miscellaneous Materials	Set	1
		Power source work & Cabling	Set	1

(bb) Interior

No	Equipment	Specification	Unit	Q'ty
1	Furniture	Office Desk	EA	13
		Partition	Set	1
		Chair (including 8 conference table chairs)	EA	21
		Printer Desk	EA	4
		Office Cabinet	EA	13

		Conference table(for 8 person)	EA	1
		File Cabinet	EA	13
2	Interior	Interior(Wall, Roof, Window etc)	Set	1

(b) RIC Configuration

No	Classification	Specification	Unit	Q'ty
1	Server and Storage System	Hardware & Software	Set	5
2	RIC Operation Office	H/W and S/W	Set	5
		Interior	Set	5
3	Multimedia Studio	H/W and S/W	Set	5
		Studio Soundproof Construction	Set	5
4	Content Development and Research Office	H/W and S/W	Set	5
		Interior	Set	5
5	Supporting Office (Central RIC)	H/W and S/W	Set	1
		Interior	Set	1
6	Supporting Office (Other RIC)	H/W and S/W	Set	4
		Interior	Set	4
7	Multimedia Classroom Type A	H/W and S/W	Set	5
		Interior	Set	5
8	Multimedia Classroom Type B	H/W and S/W	Set	5
		Interior	Set	5
9	General Classroom	H/W and S/W	Set	10

		Interior	Set	10
10	RIC Security System	RIC Security System	Set	5

(i) Server and Storage System

No	Equipment	Specification	Unit	Q'ty
1	Test Server	<ul style="list-style-type: none"> • <i>4 Core Intel Xeon 2.4GHz/10M B L3 Cache * 2EA</i> • <i>Memory: 8GB</i> • <i>300GB HDD * 2EA</i> • <i>Dual Power Supply</i> 	Set	1
2	Digital Resource Management Server	<ul style="list-style-type: none"> • <i>4 Core Intel Xeon 2.4GHz/10M B L3 Cache * 2EA</i> • <i>Memory: 8GB</i> • <i>300GB HDD * 2EA</i> • <i>Dual Power Supply</i> 	Set	1
3	DAS/NAS Storage	<ul style="list-style-type: none"> • <i>HDD: 24TB</i> • <i>High Availability Support (HA)</i> 	Set	1
4	Workgroup Switch	<ul style="list-style-type: none"> • <i>1G Fiber Ethernet: 4ports or more</i> • <i>10/100/1000 Mbps Ethernet: 24 ports or more</i> 	Set	7
5	RACK	<i>42U, KVM Switch, Panel Monitor</i>	Set	1

(ii) Operation Office

(aa) H/W & S/W

No	Equipment	Specification	Unit	Q'ty
1	Operator Computer	<ul style="list-style-type: none"> • <i>Processor: core i5-2400 processor (3.10 GHZ, 6MB) and above</i> • <i>Memory : 6GB</i> • <i>HDD: 1TB</i> • <i>Monitor: 22" LCD Monitor</i> 	Set	7
2	Digital Copier	<i>Color Print, Copy, Scan, Fax</i>	Set	1

		<ul style="list-style-type: none"> • Print Speed (Black): Up to 25 ppm • Print Speed (Color): Up to 25 ppm • Interface: USB 2.0, Ethernet 10/100/1000 Base TX 		
		Including ADF		
3	Multi Function Color Printer	Color Print, Copy, Scan, Fax <ul style="list-style-type: none"> • Print Speed (Black): 21ppm • Print Speed (Color): 21ppm • Interface: USB 2.0, Ethernet 10/100 Base TX 	Set	1
4	Consumables & Stationery	Toner for Multifunction Color Printer (Black, Minimum Printing Capacity : 2,000pages)	EA	3
		Toner for Multifunction Color Printer (Yellow, Minimum Printing Capacity : 2,000pages)	EA	3
		Toner for Multifunction Color Printer (Magenta, Minimum Printing Capacity : 2,000pages)	EA	3
		Toner for Multifunction Color Printer (Cyan, Minimum Printing Capacity : 2,000pages)	EA	3
		Toner for Digital Copier (Black, Minimum Printing Capacity : 2,000pages)	EA	2
		Toner for Digital Copier (Yellow, Minimum Printing Capacity : 2,000pages)	EA	2
		Toner for Digital Copier (Magenta, Minimum Printing Capacity : 2,000pages)	EA	2
		Toner for Digital Copier (Cyan, Minimum Printing Capacity : 2,000pages)	EA	2
5	UPS for PC	<ul style="list-style-type: none"> • Output Capacity: 450Watts / 750 VA 	Set	7
6	Video Projector & Screen	<ul style="list-style-type: none"> • Native Resolution: XGA (1024 X768) • Brightness (ANSI-Lumens): 4000ANSI 	Set	1

		Including 120" Screen		
7	Software	<i>MS-Office, Home and Business or above (latest)</i>	Set	7
8	Power & Network Cabling	Network Cabling and miscellaneous Materials	Set	1
		Power source work & Cabling	Set	1

(bb) Interior

No	Equipment	Specification	Unit	Q'ty
1	Furniture	Office Desk	EA	7
		Partition	Set	1
		Chair(including 8 conference table chairs)	EA	15
		Printer Desk	EA	1
		Office Cabinet	EA	7
		Conference table(for 8 person)	EA	1
		File Cabinet	EA	7
2	Interior	Interior(Wall, Roof, Window, etc)	Set	1
		Air Conditioner	Set	1

(iii) Multimedia Studio

(aa) H/W & S/W

N	Equipment	Specification	Unit	Q'ty
1	HD Camera System			
	HD Camera	<i>HD Camera system</i> <ul style="list-style-type: none"> • <i>Total pixels per sensor: 2.37 Mega pixels</i> • <i>Horizontal resolution: 1000 tv lines or more</i> • <i>Recording frame rate: 50Mbps: 1920 x 1080/ 60i,30p,24p; 1280x720/60p,30p, 24p</i> • <i>HD / SD-SDI OUTPUT: YES</i> 	Set	2

	Battery Pack		Set	2
	Carrying Case		Set	2
	Remote Controller		Set	2
	CF Card Reader		Set	2
	Rain Cover		Set	2
	Memory	32GB	Set	4
2	CCU for HD Camera System	<ul style="list-style-type: none"> • Camera control ch: 5ch 	Set	1
3	W/L Microphone System for HD Camera		Set	1
4	Boom Microphone System	<ul style="list-style-type: none"> • Frequency Range: 20Hz - 20kHz Including Boom Pole and Wind Screen	Set	1
5	Tripod System	for HD Camera with Prompter Head <ul style="list-style-type: none"> • Payload range: 2 to 25kg / Tripod <ul style="list-style-type: none"> • Load Capacity: >40 kg Spreader <ul style="list-style-type: none"> • Load Capacity: >50 kg Including Pan Bar, Dolly	Set	1
		for HD Camera only Head <ul style="list-style-type: none"> • Max. load: >4 kg Tripod <ul style="list-style-type: none"> • Load Capacity: >20 kg Spreader <ul style="list-style-type: none"> • Load capacity: > 40 kg Including Dolly, Carrying Bag	Set	1
6	Studio LED Line Monitor	<ul style="list-style-type: none"> • Screen Size: 42" • Resolution: 1920 x 1080p 	Set	1

		Including TV Stand		
7	Studio Monitor Speaker	<ul style="list-style-type: none"> • Powered speaker • Output Power: 70W(Dynamic Power) 	Set	2
8	Prompter	<ul style="list-style-type: none"> • Display size: 20" • Brightness: 1000 Nits • Resolution: 1280*1024 	Set	1
9	Notebook for Prompter	Including S/W <ul style="list-style-type: none"> • CPU: Intel Corei5(2.66GHz) • Display: 13.3inch • Panel resolution: 1366x768 • HDD: 320GB • Memory: 2GB DDR3 	Set	1
10	HD Switcher	<p>Video Input</p> <ul style="list-style-type: none"> • 8 simultaneous live video sources, in any combination of HD-SDI, HD Component, SD-SDI, SD Component, Y/C (BNC) or Composite connections and resolutions • Virtual: 8 independent Input <p>Video Output</p> <ul style="list-style-type: none"> • Up to 5 output connections and 2 independent A/V output signals <ul style="list-style-type: none"> • Recording: Multi-track, multi-format recording of up to 8 simultaneous channels • Live Streaming: HD live streaming via Gigabit connection 	Set	1
11	Digital Video Deck	<p>HD Format</p> <ul style="list-style-type: none"> • SDI Video Input: 4 x 10-bit SD/HD/3 Gb/s SDI switchable • SDI Video Output: 4 x 10-bit SD/HD/3G Gb/s SDI switchable 	Set	2

12	2D/3D Non-Linear Editing System	Premiere Pro CS6	Set	1
		Workstation <ul style="list-style-type: none"> • E5-2640 2.50Ghz 15MB • 1333MHz 6Core X 1EA • 16GB Memory • 1000GB 1stHDD • 1000GB 2nd HDD • 22 inch monitor 2EA 	Set	1
		Storage <ul style="list-style-type: none"> • 16TB • Host Interface: Dual 4Gb Fiber Channels 	Set	1
13	LCD Multi-view Monitor	<ul style="list-style-type: none"> • Screen Size: 42" • Resolution: 1920 x 1080p Including TV Stand	Set	1
14	PGM Monitor	<ul style="list-style-type: none"> • Size: 17inch • Resolution: 1366X768 • Contrast ratio: 900:1 • 2 HD/SD-SDI Input 	Set	1
15	HDV VTR	<ul style="list-style-type: none"> • Recording format: HDV1080/60i, 1080/50i, 1080/24p, 1080/25p, 1080/30p • Playout format: HDV1080/60i, 1080/50i, 1080/24p, 1080/25p, 1080/30p. 	Set	1
16	Sync Generator	<ul style="list-style-type: none"> • HD Sync 	Set	1
17	Blue Ray Player	<ul style="list-style-type: none"> • HDMI out: 19 pin (Type A, HDMI™ Connector) • Digital Audio Output : Optical 	Set	1

18	HD-SDI Router	<ul style="list-style-type: none"> • Port: 8 Input / 8 Output 	Set	1
19	Audio Distribution AMP	<p>Input</p> <ul style="list-style-type: none"> • Number of Input: 1In <p>Output</p> <ul style="list-style-type: none"> • Number of Output: 6 Out 	Set	1
20	Interactive Display Board	<ul style="list-style-type: none"> • Size: 82"LED Panel • 16:9 aspect ratio • Resolution: 1920×1080P, Full HD • Contrast : 5000:1 	Set	1
21	Audio Mixer	<p>16CH Digital Audio Mixer</p> <ul style="list-style-type: none"> • Chanel: 1~16 Microphones/Lines <p>Digital Input</p> <ul style="list-style-type: none"> • 2TR IN Digital: RCA Pin Jack • ADAT In: Optical <p>Digital Output</p> <ul style="list-style-type: none"> • 2TR Out Digital: RCA Pin Jack • ADAT Out: Optical 	Set	1
22	Control Room Monitor Speaker	<ul style="list-style-type: none"> • Powered speaker • Output Power: 70W(Dynamic Power) 	Set	2
23	Wired Microphone	<ul style="list-style-type: none"> • Frequency response: 80 – 15,000 Hz <p>Including stand</p>	Set	2
	Gooseneck Microphone	<ul style="list-style-type: none"> • Polar Pattern: Hyper-cardioid • Frequency response: 70 Hz - 18 kHz <p>Including stand</p>	Set	1
24	W/L Microphone	<ul style="list-style-type: none"> • Frequency response: 25~18,000 Hz 	Set	2

25	Headphone	<ul style="list-style-type: none"> • Dynamic • Frequency range: 12Hz to 28kHz 	Set	1
26	Network Switch	<ul style="list-style-type: none"> • Connectors: 16 10BASE-T/100BASE-X/1000BASE-T, 4 Gigabit SFP ports 	Set	1
27	Intercom System	Including Headset 3EA, Belt-pack 2EA	Set	1
28	Back-Up System	LTO Backup System	Set	1
		<ul style="list-style-type: none"> • Transfer Rate - 100MB/s direct attached, - up to 75 MB/s network • Hard Disk Drive - 2000 GB X 2 – RAID0/1 		
		LTO-5 Tape 1.5TB		
		Cleaning Tape	EA	1
29	On air Lamp	LED Type	Set	2
30	UPS	Output Power Capacity: 10 kVA	Set	2
31	Chromakey Screen	150"	Set	1
32	Console Desk	5Bay	Set	1
33	NLE Desk	Wood	Set	1
34	Power Distributer	1 in 8out	Set	2
35	System Rack	19", 42U	Set	1

(bb) Studio Soundproof Construction

N	Equipment	Specification	nit	Q'ty
1	Soundproof Interior	Soundproof system and doors, dustproof system, Furniture Soundproof Door - Materials : Al 1.5T ~ 2.0T - Sound Reduction Index : 35 ~ 45dB Soundproof Window - Triplex Soundproof Glasses - Materials : St'1 2.3T, Al 3.0T	Set	1

		- Sound Reduction Index : 40 ~ 50dB <i>* The bidder shall submit a certificate of soundproof test issued by an authorized agency in the country of origin.</i>		
2	Power Cabling & Installation	Power/Network/Audio Visual Signal Cabling & Installation <i>* For Audio/Visual Signal Cabling, Cables and connectors meeting international standards and ensuring high-quality audio/video transmission shall be used.</i>	Set	1
3	Studio Lighting	Special Lighting(Fly Duct, Horizon, Spot, Control Panel, etc)	Set	1

(iv) Content Development and Research (CDR) Office

(aa) H/W & S/W

No	Equipment	Specification	Unit	Q'ty
1	Operator Computer	<ul style="list-style-type: none"> • Processor: Intel core i5-2400 processor (3.10 GHZ,6MB) and above, • Memory: 6GB • HDD: 1TB • Monitor: 22" LCD Monitor * 2EA 	Set	10
2	Multi Function Color Printer	Color Print, Copy, Scan, Fax <ul style="list-style-type: none"> • Print Speed (Black): 21ppm • Print Speed (Color): 21ppm • Interface: USB 2.0, Ethernet 10/100 Base TX 	Set	2
3	UPS for PC	Output Capacity: 450Watts / 750 VA	Set	10

4	Digital Copier	<p>Color Print, Copy, Scan, Fax</p> <ul style="list-style-type: none"> • Print Speed (Black): Up to 25 ppm • Print Speed (Color): Up to 25 ppm • Interface: USB 2.0, Ethernet 10/100/1000 Base TX <p>Including ADF</p>	Set	1
5	Digital camera	<ul style="list-style-type: none"> • Effective Pixel: Approx. 20.3 Mega-pixels • Video Out: NTSC, PAL (user selectable), HDMI 1.4a: (1080i, 720P, 576P / 480P) <p>Including Tripod, Rechargeable Battery, Bag, Lens(18~55mm Lens), 32GB Memory card, Compatible Microphone</p>	Set	2
6	HD Camcorder	<p>HD Camcorder</p> <ul style="list-style-type: none"> • Type: 1080p HD Switch Grip Camcorder • Lens: Optical Zoom: 20x, Digital Zoom: 40x • Resolution: Full HD <p>Including Tripod, Bag, 32GB Memory card</p>	Set	2
7	Video Projector & Screen	<ul style="list-style-type: none"> • Native Resolution: XGA (1024x768) • Brightness (ANSI-Lumens): 4000ANSI <p>Including 120" Screen</p>	Set	1
8	Consumables & Stationery	Toner for Multifunction Color Printer (Black, Minimum Printing Capacity : 2,000pages)	EA	5
		Toner for Multifunction Color Printer (Yellow, Minimum Printing Capacity : 2,000pages)	EA	5
		Toner for Multifunction Color Printer (Magenta, Minimum Printing Capacity : 2,000pages)	EA	5
		Toner for Multifunction Color Printer (Cyan, Minimum Printing Capacity : 2,000pages)	EA	5
		Toner for Digital Copier (Black,	EA	3

		Minimum Printing Capacity : 2,000pages)		
		Toner for Digital Copier (Yellow, Minimum Printing Capacity : 2,000pages)	EA	3
		Toner for Digital Copier (Magenta, Minimum Printing Capacity : 2,000pages)	EA	3
		Toner for Digital Copier (Cyan, Minimum Printing Capacity : 2,000pages)	EA	3
9	CD/DVD Duplicator	1:1 Duplication , stand alone • Reader: 18X DVD Rom • Writer: 24X DVD Recorder	Set	1
10	CD/DVD Printer	Inkjet Printer • Supported Media: CDs, DVDs, Blu-ray Discs, and HD-DVDs • Disc Input: 100	Set	1
11	DAS /NAS Storage for RIC content backup	• HDD: 8TB • Network: 2 Gigabit Ethernet	Set	1
12	Software	MS-Office, Office University 2010 or above (latest)	Set	10
		Creative Suite 6 Design & Web Premium Student and Teacher Edition or above (latest)	Set	2
		Creative Suite 6 Production Premium Student and Teacher Edition or above (latest)	Set	2
		Creative Suite 6 Master Collection Student and Teacher Edition or above (latest)	Set	2
		Autodesk 3D Max Design 2013, Subscription (1 year) or above (latest)	Set	1
		Corel painter 12 or above (latest)	Set	2
		CorelDRAW Graphics Suite X6 or above (latest)	Set	2
		Sound Forge Pro 10 or above (latest)	Set	2
13	Blank DVD	DVD-R, 4.7GB 16X 50P, Printable	Set	800

14	Power & Network Cabling	Network Cabling and miscellaneous Materials	Set	1
		Power source work & Cabling	Set	1

(bb) Interior

No	Equipment	Specification	Unit	Q'ty
1	Furniture	Office Desk	EA	10
		Partition	Set	1
		Chair(including 8 conference table chairs)	EA	18
		Printer Desk	EA	2
		Office Cabinet	EA	8
		Conference table(for 8 people)	EA	1
		File Cabinet	EA	10
2	Interior	Interior(Wall, Roof, Window, etc)	Set	1
		Air Conditioner	Set	1

(v) Supporting office (Central RIC)

(aa) H/W & S/W

No	Equipment	Specification	Unit	Q'ty
1	Operator Computer	<ul style="list-style-type: none"> • Processor: Intel core i5-2400 processor (3.10 GHZ,6MB) and above, • Memory: 6GB • HDD: 1TB • Monitor: 22" LCD Monitor * 2EA 	Set	19
2	Notebook computer	<ul style="list-style-type: none"> • CPU: Intel Core i5 Processor 3317U, up to 2.60GHz, 3MB cache or higher • Screen Size: 14" • Resolution: 1366 X 768 • Memory: 6GB DDR3 • HDD: 500GB 	Set	8
3	Potable Station	Chargeable, Locking, Portable, Charging system	Set	1

4	Software	<i>MS-Office, Office University 2010 or above (latest)</i>	Set	27
		<i>Creative Suite 6 Design & Web Premium Student and Teacher Edition or above (latest)</i>	Set	4
		<i>Creative Suite 6 Production Premium Student and Teacher Edition or above (latest)</i>	Set	5
		<i>Creative Suite 6 Master Collection Student and Teacher Edition or above (latest)</i>	Set	4
		<i>Corel painter 12 or above (latest)</i>	Set	1
		<i>CorelDRAW Graphics Suite X6 or above (latest)</i>	Set	1
5	Power & Network Cabling	Network Cabling and miscellaneous Materials	Set	1
		Power source work & Cabling	Set	1

(bb) Interior

No	Equipment	Specification	Unit	Q'ty
1	Furniture	Office Desk	EA	27
		Chair	EA	27
2	Interior	Air Conditioner	Set	1

(vi) Supporting office (Other 4 RIC)

(aa) H/W & S/W

No	Equipment	Specification	Unit	Q'ty
1	Operator Computer	<ul style="list-style-type: none"> • Processor: Intel core i5-2400 processor (3.10 GHZ,6MB) and above, • Memory: 6GB • HDD: 1TB • Monitor: 22" LCD Monitor * 2EA 	Set	14
2	Notebook computer	<ul style="list-style-type: none"> • CPU: Intel Core i5 Processor 3317U, up to 2.60GHz, 3MB cache or higher • Screen Size: 14" • Resolution: 1366 X 768 	Set	8

		<ul style="list-style-type: none"> • Memory: 6GB DDR3 • HDD: 500GB) 		
3	Potable Station	Chargeable, Locking, Portable, Charging system	Set	1
4	Software	MS-Office, Office University 2010 or above (latest)	Set	22
		Creative Suite 6 Design & Web Premium Student and Teacher Edition or above (latest)	Set	3
		Creative Suite 6 Production Premium Student and Teacher Edition or above (latest)	Set	3
		Creative Suite 6 Master Collection Student and Teacher Edition or above (latest)	Set	3
		Corel painter 12 or above (latest)	Set	1
		CorelDRAW Graphics Suite X6 or above (latest)	Set	1
5	Power & Network Cabling	Network Cabling and miscellaneous Materials	Set	1
		Power source work & Cabling	Set	1

(bb) Interior

No	Equipment	Specification	Unit	Q'ty
1	Furniture	Office Desk	EA	22
		Chair	EA	22
2	Interior	Air Conditioner	Set	1

(vii) Multimedia Classroom Type A

(aa) H/W & S/W

No	Equipment	Specification	Unit	Q'ty
A. Electronic Desk Board				

1	PC for Trainer	<ul style="list-style-type: none"> • Processor: Intel core i5-2400 processor(3.10 GHZ,6MB) and above • Memory: 6GB • HDD: 1TB • Monitor: 22" LCD Monitor <p>Including HD Encoder</p>	Set	1
2	PC for Trainee	<ul style="list-style-type: none"> • Processor: Intel core i5-2400 processor (3.10 GHZ,6MB) and above • Memory: 6GB(• HDD: 1TB • Monitor: 22" LCD Monitor 	Set	30
3	Multi Function Color Printer	<p>Color Print, Copy, Scan, Fax</p> <ul style="list-style-type: none"> • Print Speed (Black): 21ppm • Print Speed (Color): 21ppm • Interface: USB 2.0, Ethernet 10/100 Base TX 	Set	2
4	Software	MS-Office, Office University 2010	Set	31
5	e-Podium	Including Touch Monitor	Set	1
6	Interactive Display Board	<ul style="list-style-type: none"> • Size: 82"LED Panel • 16:9 aspect ratio • Resolution: 1920×1080P, Full HD • Contrast : 5000:1 	Set	1
B. Audio System				
1	Wireless Microphone Set	<p>Hand Type and Tie Type</p> <ul style="list-style-type: none"> • RF Transmitter Output: 30mW Maximum <p>Comply with frequency rate of Colombia</p>	Set	2
2	Wired Microphone	<ul style="list-style-type: none"> • Frequency Response: 50 to 15,000 Hz <p>Including 10m Cable</p>	Set	2
3	DSP Mixer	<ul style="list-style-type: none"> • Acoustical Echo Cancellation • Noise Cancellation • 4 X 35W speaker amp 	Set	1

		• 12 Analog in/out		
4	Ceiling Speaker	Power handling : 20 W	Set	8
C. Video System				
1	HD Matrix Switcher	• RGBHV+Stereo, 8in 8out	Set	1
2	Visual Presenter	• Camera Module: 42X Zoom, 1,300,000 pixels	Set	1
3	Video Conference System	<ul style="list-style-type: none"> • People Video Resolution : 720p, 30fps at 1 Mbps–2 Mbps (7002) • Video Standard and Protocols :H.264 / H.263++ / H.261 / H.239 / People+Content / H.263 & H.264 Video Error Concealment Including Document Share Function	Set	1
4	Camera	<ul style="list-style-type: none"> • PTZ Camera • Video signal: 1080/59.94i, 1080/50i, 1080/29.97p, 1080/25p, 720/59.94p, 720/50p/720/29.97p, 720/25p ntsc/pal 	Set	2
5	Motion Detection Camera System	Sensor Camera, Motion Tracking Controller, S/W	Set	1
6	Monitor	<ul style="list-style-type: none"> • Screen Size: 42" • Resolution: 1920 x 1080p Including ceiling type bracket	Set	2
D. Classroom Control System				
1	Controller	7 Configurable RS-232 / RS-422 / RS-485 Serial ports, 8 Relays, 8 IR / Serial ports	Set	1
2	Lecture Touch Control Panel	4.3" Touch	Set	1
3	Wireless Touch Panel	9.7" LED Wide	Set	1
4	iPad License	License using iPad	Set	1
5	Program fee		Set	1
6	Class management S/W	1Teacher, 30 Student License	Set	1

E. Miscellaneous				
1	UPS	Output Power Capacity: 10 kVA	Set	1
2	UPS for PC	Output Capacity: 450Watts / 750 VA	Set	31
3	Rack	19"	Set	1
4	Power & Network Cabling	Network Cabling and miscellaneous Materials	Set	1
		Power source work and Cabling	Set	1

(bb) Interior

N	Equipment	Specification	Unit	Q' y
1	Furniture	Computer Desk for Trainee	EA	30)
		Chair	EA	31
		Printer Desk	EA	2
2	Interior	Interior(Wall, Roof, Window, etc)	Set	1
		Air Conditioner	Set	1

(viii) Multimedia Classroom Type B

(aa) Interior

No	Equipment	Specification	Unit	Q'ty
A. Electronic Desk Board				
1	PC for Trainer	<ul style="list-style-type: none"> • Processor: Intel core i5-2400 processor(3.10 GHZ,6MB) and above • Memory: 6GB • HDD: 1TB • Monitor: 22" LCD Monitor Including HD Encoder	Set	1
2	PC for Trainee	<ul style="list-style-type: none"> • Processor: Intel core i5-2400 processor (3.10 GHZ,6MB) and above • Memory: 6GB(• HDD: 1TB • Monitor: 22" LCD Monitor 	Set	30
3	Multi Function Color Printer	Color Print, Copy, Scan, Fax <ul style="list-style-type: none"> • Print Speed (Black): 21ppm 	Set	2

		<ul style="list-style-type: none"> • Print Speed (Color): 21ppm • Interface: USB 2.0, Ethernet 10/100 Base TX 		
4	Software	MS-Office, Office University 2010	Set	31
5	e-Podium	Including Touch Monitor	Set	1
6	Interactive Display Board	<ul style="list-style-type: none"> • Size: 82" LED Panel • 16:9 aspect ratio • Resolution: 1920×1080P, Full HD • Contrast : 5000:1 	Set	1
B. Audio System				
1	Wireless Microphone Set	<p>Hand Type and Tie Type</p> <ul style="list-style-type: none"> • RF Transmitter Output: 30mW Maximum <p>Comply with frequency rate of Colombia</p>	Set	2
2	Wired Microphone	<ul style="list-style-type: none"> • Frequency Response: 50 to 15,000 Hz <p>Including 10m Cable</p>	Set	2
3	DSP Mixer	<ul style="list-style-type: none"> • Acoustical Echo Cancellation • Noise Cancellation • 4 X 35W speaker amp • 12 Analog in/out 	Set	1
4	Ceiling Speaker	Power handling : 20 W	Set	8
C. Video System				
1	HD Matrix Switcher	• RGBHV+Stereo, 8in 8out	Set	1
2	Visual Presenter	• Camera Module: 42X Zoom, 1,300,000 pixels	Set	1
D. Classroom Control System				
1	Controller	7 Configurable RS-232 / RS-422 / RS-485 Serial ports, 8 Relays, 8 IR / Serial ports	Set	1
2	Lecture Touch Control Panel	4.3" Touch	Set	1
3	Wireless Touch Panel	9.7" LED Wide	Set	1
4	iPad License	License using iPad	Set	1
5	Program fee		Set	1
6	Class management	1Teacher, 30 Student License	Set	1

	S/W			
E. Miscellaneous				
1	UPS	Output Power Capacity: 10 kVA	Set	1
2	UPS for PC	Output Capacity: 450Watts / 750 VA	Set	31
3	Rack	19"	Set	1
4	Power & Network Cabling	Network Cabling and miscellaneous Materials	Set	1
		Power source work and Cabling	Set	1

(bb) Interior

N	Equipment	Specification	Unit	Q' y
1	Furniture	Computer Desk for Trainee	EA	30
		Chair	EA	31
		Printer Desk	EA	2
2	Interior	Interior (Wall, Roof, Window, etc)	Set	1
		Air Conditioner	Set	1

(ix) General Classroom

(aa) H/W & S/W

No	Equipment	Specification	Unit	Q'ty
A. Electronic Desk Board				
1	PC for Trainer	<ul style="list-style-type: none"> • Processor: Intel core i5-2400 processor(3.10 GHZ,6MB) and above • Memory: 6GB • HDD: 1TB • Monitor: 22" LCD Monitor 	Set	1
2	PC for Trainee	<ul style="list-style-type: none"> • Processor: Intel core i5-2400 processor(3.10 GHZ,6MB) and above • Memory: 6GB • HDD: 1TB • Monitor: 22" LCD Monitor 	Set	15
3	Multi Function Color Printer	Color Print, Copy, Scan, Fax <ul style="list-style-type: none"> • Print Speed (Black): 21ppm • Print Speed (Color): 21ppm 	Set	2

		• Interface: USB 2.0, Ethernet 10/100 Base TX		
4	Software	MS-Office, Office University 2010	Set	16
5	e-Podium	Including Touch Monitor	Set	1
6	Video Projector and Screen	• Native Resolution: XGA (1024x768) • Brightness (ANSI-Lumens): 4000ANSI Including 120” motorized screen	Set	1
B. Audio System				
1	Wireless Microphone	Hand Type and Tie Type • RF Transmitter Output: 30mW Maximum Comply with frequency rate of Colombia	Set	2
2	Wired Microphone	• Frequency Response: 50 to 15,000 Hz Including 10m Cable	Set	2
3	DSP Mixer	• Acoustical Echo Cancellation • Noise Cancellation • 4 X 35W speaker amp • 12 Analog in/out	Set	1
4	Ceiling Speaker	Power handling : 20 W	Set	8
C. Video System				
1	HD Matrix Switcher	• RGBHV+Stereo, 8in 8out	Set	1
2	Visual Presenter	• Camera Module: 42X Zoom, 1,300,000 pixels	Set	1
D. Classroom Control System				
1	Controller	7 Configurable RS-232 / RS-422 / RS-485 Serial ports, 8 Relays, 8 IR / Serial ports	Set	1
2	Lecture Touch Control Panel	4.3" Touch	Set	1
3	Wireless Touch Panel	9.7" LED Wide	Set	1
4	iPad License	License for using iPad	Set	1
5	Program fee		Set	1
6	Class management S/W	1Teacher, 15 Student License	Set	1

E. Miscellaneous				
1	UPS	Output Power Capacity: 10 kVA	Set	1
2	UPS for PC	Output Capacity: 450Watts / 750 VA	Set	16
3	Rack	19"	Set	1
4	Power & Network Cabling	Network Cabling and miscellaneous Materials	Set	1
		Power source work and Cabling	Set	1

(bb) Interior

No	Equipment	Specification	Unit	Q't
1	Furniture	Computer desk for Trainee (1 desk for 2 trainees)	EA	15
		Chair	EA	31
		Printer Desk	EA	2
2	Interior	Interior(Wall, Roof, Window, etc)	Set	1
		Air Conditioner	Set	1

(x) RIC Security System

N	Equipment	Specification	Unit	Q'ty
1	Camera	Fixed Dome Camera <ul style="list-style-type: none"> • Pixels: 410,000 Pixels, 811(H) X 494(V) • Horizontal Resolution: 600TV Line(Color), 700TV Line(B/W) 	Set	10
2	Motion Detection Sensor	Motion Detection Sensor (8 sets)& Door Sensor (10 sets)	Set	1
3	DVR	<ul style="list-style-type: none"> • Video Input: Composite 16CH • Audio: 16CH In/1CH Out • Resolution: up to 480FPS @ 704X480 • HDD: 1TB <p>Including 17" Monitor</p>	Set	1
4	UPS	Output Power Capacity: 5 KVA	Set	1
5	Rack	19", Height: 22U	Set	1

(c) Lab School(Pilot School)

Lab Schools are to provide computers and software for class to evaluate the quality of the teachers who have received the Teacher training and of the content developed by RIC.

The wireless network environment is to be established for Lab Schools so that mobile equipment can be utilized through designated places of the schools.

No	Equipment	Specification	Unit	Q'ty
1	Firewall S/W	<ul style="list-style-type: none"> • <i>Anti-Virus</i> • <i>Child Protection</i> 	Set	50
2	Network Switch	<ul style="list-style-type: none"> • <i>Ports: 22 autosensing 10/100/1000 ports</i> 	Set	50
3	Proxy Server	<ul style="list-style-type: none"> • <i>Processor: Intel Xeon Quad-Core W3520(2.66GHz, 8MB cache, 1066Mhz Memory) * 1EA</i> • <i>Memory: 4GB</i> • <i>HDD: 500GB</i> • <i>22" LCD Monitor</i> 	Set	50
4	Access Point (WiFi)	<ul style="list-style-type: none"> • <i>802.11a/b/g, 54Mbps</i> 	Set	300
5	Notebook	<ul style="list-style-type: none"> • <i>CPU: Intel Core i5 Processor 3210M, 2.60Ghz, 3MB or higher</i> • <i>Screen Size: 15.6"</i> • <i>Resolution: 1366 X 768</i> • <i>Memory: 6GB</i> • <i>HDD: 500GB</i> 	Set	1100
6	Software	MS-Office, Home and Student	copy	1100
7	Multi Function Printer	<p><i>Color Print, Copy, Scan</i></p> <ul style="list-style-type: none"> • <i>Print Speed (Black): 17ppm or higher</i> • <i>Print Speed (Color): 4ppm</i> • <i>Interface: High-Speed USB 2.0 / 10/100 Base Tx</i> 	Set	100
8	Toner	Toner for Multifunction Color Printer (Black, Minimum Printing Capacity : 2,000pages)	EA	300

		Toner for Multifunction Color Printer (Yellow, Minimum Printing Capacity : 2,000pages)	EA	300
		Toner for Multifunction Color Printer (Magenta, Minimum Printing Capacity : 2,000pages)	EA	300
		Toner for Multifunction Color Printer (Cyan, Minimum Printing Capacity : 2,000pages)	EA	300
9	Projector and Portable Screen	<ul style="list-style-type: none"> • Native Resolution: XGA(1024x768) • Brightness(ANSI-Lumens): 3200ANSI Including Potable 120" Screen	Set	100
10	Potable Station	Chargeable, Locking, Portable, Charging system	Set	100
11	UPS	Capacity: 3000VA	Set	50
12	Power Extension	6 Socket, 3M	Set	200
13	Classroom Management S/W	2 Teacher License, 20 Student License	Set	50

2.5 General Requirements

- (a) The Purchaser seeks to provide H/W and S/W for 1 NIC, 5 RICs and 50 Lab Schools including cabling routes, methods, etc., with cable of Category 7A supporting IpV6 protocol.
- (b) The Bidder shall propose a plan to supply, deliver and install the Deliverables specified above that best serve the Purchaser's objectives.
- (c) The Bidder shall propose an optimized system.
- (d) The Bidder shall propose H/W and S/W compatible with those currently operated by the Ministry of Education of Colombia.
- (e) The Bidder shall clearly specify the major functions, specification, features, data and validity for the proposed products.
- (f) The Bidder shall consider the market price of Colombia when proposing the price for each H/W and S/W. The proposed price must not be higher than that of Colombia.
- (g) The Bidder shall ensure the service environment and equipment compatibility between NIC and 5 RICs.
- (h) The Supplier shall be responsible for supply, delivery, and installation of equipment for 50 Lab Schools, 10 for each RIC.

- (i) The Bidder shall propose a plan to configure Lab Schools with Wi-Fi environment. Lab Schools are to be asked to select 6-8 classrooms designated for ICT class.
- (j) Warranty period of all H/W and S/W related to NIC/RIC is 1 year after the Acceptance Test is complete. However, the Bidder may propose additional warranty period.
- (k) The Bidder shall hire a customs intermediation agency (Colombian term of the SIA (Sociedad de Intermediación Aduanera) in Colombia to assist for all the customs related work.

2.6 Technical Requirements

The Bidder shall propose a H/W and S/W on the basis of the following information;

- (a) NIC
 - (i) NIC overall technical requirements
Refer to the Section 3.
 - (ii) e-Portal H/W & S/W
Refer to the Section 3.
 - (iii) NIC Operation office
 - (aa) All the computers are connected to each other, to server, to printer and to digital copier through network.
 - (bb) Computers and Monitors shall be connected to the proposed UPS. Proposed UPS shall be supported (customer service available) by authorized reseller(s) in Colombia. Due to frequent electricity outages, presence of local authorized reseller (with customer service personnel) is mandatory.
 - (cc) Computers shall be connected to the intranet of the Ministry of Education of Colombia.
 - (dd) The Bidder shall propose an installation plan for equipment, network cabling, power cabling, etc., including cabling routes, methods, etc., with LAN cable of Category 7A supporting IPv6 protocol and 20 years factory warranty. The connection shall be functional with the existing and/or new connection.
 - (ee) The Bidder may provide a list of additional equipment, if any, to be used to install the equipment.
 - (ff) The Bidder shall propose a space plan for the Operation

office with the interior design method.

(b) RIC

(i) RIC overall technical requirements

- (aa) 5 RICs are to be established throughout Colombia in separate regions. Floor plans of each RIC are attached separately.
- (bb) Each RIC has two networks, Internet and RENATA, and the Bidder shall propose a network system to connect these 2 networks. Expected network speed for the 2 networks upon commencement of the Project is as follow.

	Internet	RENATA	Remark
NIC	100 Mbps (40Mbps for leased line)	50 Mbps	Colombia Aprende
RIC	20 Mbps	50 Mbps	

RENATA is to be designed to upload/download the content between Colombia Aprende and RIC.

- (cc) The Bidder shall propose a system design to connect the current network of RIC.
- (dd) The Bidder shall propose H/W and S/W whose maintenance is possible in Colombia. In case maintenance of such H/W and S/W are not possible, the Bidder shall propose a separate plan to realize the maintenance.
- (ee) All video/audio equipment to be proposed shall abide by the TV signal standards of Colombia (NTSC) and OS and keyboards shall support Spanish language (Latin American configuration).
- (ff) Space to establish rooms of RIC shall be provided by each RIC and the Supplier shall be responsible for interior design, network/power cabling, furniture layout and supply, delivery and installation of the equipment.
- (gg) The Bidder shall propose an electricity plan with required electricity for each room and requested location of power distribution boxes. RIC shall be responsible for power cabling from the main power distribution center to the power distribution boxes of all rooms.
- (hh) The Supplier shall be responsible for the power cabling

from the distribution box to equipment except lighting.

- (ii) The Bidder shall acknowledge that the number of equipment on the Deliverables is minimum requirements. The Bidder shall review thoroughly the attached floor plan to propose adequate number of equipment.
 - (jj) The Bidder shall propose a space plan for each room of RIC including detailed electricity/network cabling and interior design plan.
 - (kk) Proposed UPS shall be supported (customer service available) by authorized reseller(s) in Colombia. Due to frequent electricity outages, presence of local authorized reseller (with customer service personnel) is mandatory.
 - (ll) The bidder shall calculate and propose the architectural volume of each room of RIC and propose air conditioning system according to that calculated volume.
 - (mm) The bidder shall propose plan to preserve and protect cultural heritage for Central RIC.
- (ii) RIC Server and Storage System
- (aa) The Bidder shall propose a network cabling plan to connect the server room of RIC to all other RIC rooms with LAN cable of Category 7A supporting IPv6 protocol and 20 years factory warranty. The connection shall be functional with the existing and/or new connection each RIC provides.
 - (bb) All PC shall be connected to both the test server and the digital resource management server to be placed at the server room.
 - (cc) The Bidder shall propose a plan to separate the RIC network with the current network of RIC to restrict access from any unauthorized users.
 - (dd) The Bidder shall propose H/W and S/W that are compatible with H/W and S/W for NIC (e-Portal H/W and S/W).
- (iii) RIC Operation Office
- (aa) All computers shall be connected to each other, to server, to printer and to digital copier through the network.
 - (bb) Computers and Monitors shall be connected to the proposed UPS.
 - (cc) The Bidder shall propose an installation plan for equipment, network cabling, power cabling, etc including

cabling routes, methods, etc.

- (dd) The Bidder may provide a list of additional equipment, if any, to be used to install the equipment.
 - (ee) The Bidder shall propose a space plan for the Operation office with the interior design method.
- (iv) RIC Multimedia Studio
- (aa) It is recommended that the Supplier use cables and connectors that abide by all international standards.
 - (bb) Video cables shall be able to transmit HD signal and cables of 4C and above shall be used.
 - (cc) Phases of power for system (10Kw) and lighting (10Kw) shall be separated. In case the Supplier finds that the capacity of power required for the studio exceeds the capacity stated above, the Supplier may propose the required power capacity.
 - (dd) Non-Linear Editing System shall be connected to VCR and HD Switcher for effective editing.
 - (ee) The control room and the Content Development and Research office shall be connected through network for file sharing.
 - (ff) All cameras shall be equipped with 'tally system' for showing broadcasting images and it should be easily identifiable whether it's active or inactive.
 - (gg) Communication channel must be established between camera operators and producers using intercom system.
 - (hh) The system design of studio shall follow international broadcasting standard.
- (v) RIC Content Development and Research (CDR) Office
- (aa) All computers shall be connected to each other, to server, to printer and to digital copier through the network.
 - (bb) Computers and Monitors shall be connected to the proposed UPS.
 - (cc) The Bidder shall propose an installation plan for equipment, network cabling, power cabling, etc including cabling routes, methods, etc., with LAN cable of Category 7A supporting IPv6 protocol and 20 years factory warranty. The connection shall be functional with the existing and/or new connection each RIC provides.
 - (dd) The Bidder may provide a list of additional equipment, if

any, to be used to install the equipment.

- (ee) The Bidder shall propose a space plan for the Operation office with the interior design method.
- (vi) RIC Supporting Office
 - (aa) RIC will additionally provide space for supporting office.
 - (bb) All computers shall be connected to each other and to server through the network.
- (vii) RIC Multimedia Classroom
 - (aa) All computers shall be connected to each other, to server, to printer and to digital copier through the network.
 - (bb) Computers and Monitors shall be connected to the proposed UPS.
 - (cc) The Bidder shall propose an installation plan for equipment, network cabling, power cabling, etc including cabling routes, methods, etc., with LAN cable of Category 7A supporting IPv6 protocol and 20 years factory warranty. The connection shall be functional with the existing and/or new connection each RIC provides.
 - (dd) The Bidder may provide a list of additional equipment, if any, to be used to install the equipment.
 - (ee) The Bidder shall propose a space plan for the Operation office with the interior design method.
 - (ff) The Bidder shall propose HD based video conferencing system.
 - (gg) The Bidder shall propose a space plan in consideration of the effective utilization of secondary monitor.
 - (hh) The bidder shall complete establishing at least one multimedia classroom of the Central RIC within the end of the first 3rd month of the project to accommodate the staffs for the pilot project of the content development (3 people from each RIC plus 3 trainers from the Supplier).
- (viii) RIC General Classroom
 - (aa) All computers shall be connected to each other, to server, to printer and to digital copier through the network.
 - (bb) Computers and Monitors shall be connected to the proposed UPS.
 - (cc) The Bidder shall propose an installation plan for equipment, network cabling, power cabling, etc including

cabling routes, methods, etc., with LAN cable of Category 7A supporting IPv6 protocol and 20 years factory warranty. The connection shall be functional with the existing and/or new connection each RIC provides.

- (dd) The Bidder may provide a list of additional equipment, if any, to be used to install the equipment.
- (ee) The Bidder shall propose a space plan for the Operation office with the interior design method.
- (ix) RIC Security System
 - (aa) The Proposed system shall cover all the areas of RIC facilities. The deliverables are minimum requirement and the Bidder may propose additional equipment.
 - (bb) The Bidder shall propose a unique plan for each RIC to reflect the locations of RIC facilities.
 - (cc) DVR system shall support Spanish language.
 - (dd) The Bidder may provide a list of additional equipment for access control system (using the RFID technology). The proposed equipment should be compatible with the DVR system.
- (c) Lab Schools
 - (i) Proposed equipment such as notebook, printer, projector, proxy server shall support Spanish language.
 - (ii) Proposed portable stations shall include recharging system with locking mechanism.
 - (iii) Required AP may vary by each Lab School. The Bidder may propose additional number of AP.
 - (iv) The Bidder shall propose a plan to utilize a proposed proxy server to connect to Colombia Aprende. Proxy server is designed to download the content from Colombia Aprende and use it in classroom.
 - (v) The Bidder shall propose a classroom management solution to include functions to control/monitor students' screen and to transmit the teacher's screen to students' screen.

2.7 Functional Requirements

The Bidder shall propose a H/W and S/W on the basis of the following information;

- (a) NIC

- (i) NIC overall functional requirements
Refer to the Section 3.
- (ii) e-Portal H/W & S/W
Refer to the Section 3.
- (iii) NIC Operation office
 - (aa) NIC Operation office is to be established in the Ministry of Education of Colombia.
 - (bb) Refer to the attached floor plan for detailed information.
 - (cc) The Bidder shall bear responsibility to support the cost of the Help Desk to run 6 staff for 12 months. No additional H/W or S/W is required but only the operational cost.
- (b) RIC
 - (i) RIC overall functional requirements
 - (aa) Refer to the technical requirements
 - (ii) RIC Server and Storage System
 - (aa) The Bidder shall propose a digital repository system for NIC to monitor the content information stored in DAS storage of RIC.
 - (bb) The Bidder shall propose a plan for NIC or the Ministry of Education of Colombia to manage the content developed by 5 RIC.
 - (iii) RIC Operation Office
 - (aa) The Bidder shall propose required equipment including interior design.
 - (bb) Refer to the attached floor plan for detailed information.
 - (iv) RIC Multimedia Studio
 - (aa) Control Room shall be designed for basic editing.
 - (bb) All Studio system shall be synchronized.
 - (cc) The Studio system shall be established for instant encoding at the same time the video capturing at the control room.
 - (dd) The standard of video signal shall be HD-SDI (support 1080p, except HDV VTR), and TV signal shall support NTSC.
 - (ee) Storage for saving and sharing content shall be established. DAS storage type for easy access to the content by CDR

staff is highly recommended.

- (ff) HD camera system shall have the following functions:
 - a. HD-SDI signal processing.
 - b. Visual recording shall support 50Mbps, 4:2:2 and be saved with MXF format
 - c. Image sensor shall be over 2,000,000pixel
- (gg) HD switcher system shall have the following functions:
 - a. Virtual studio, live switching, multi channel recoding, multi-view, live streaming, text and graphic overlay function, and signal monitoring functions
 - b. Function to record multi-track, multi-format(QuickTime, MPEG-2, AVI, H.264)
 - c. Function to share computer screens or displays from network connected (Windows® or OS X® based) computer systems
 - d. Function to connect any combination of HD-SDI, HD Component, SD-SDI, SD Component, Y/C (BNC) or Composite connections and resolutions
 - e. Multi-track, multi-format recording of all input channel(up to 8 simultaneous channels)
 - f. 8 or above HD SDI signal input
- (ff) Multimedia studio shall be constructed with the following conditions:
 - a. Studio shall comply with international standards. The Bidder shall propose the expected reverberation time and noise level. The requirements are as follow:
 - i.* Reverberation time: $RT60=0.5\sim 0.8\text{sec}$
 - ii.* Noise level: Less than 34dB(A)
 - b. The Bidder shall acknowledge that each Multimedia Studio of RIC has different space and conditions. Refer to the attached floor plan to propose appropriate design of each Studio.
 - c. The Bidder shall propose a fire-proof and fire extinguishing installations.
 - d. The Bidder shall propose an air conditioning system for the Studio.

- e. The Bidder shall propose a sound-proof (isolation) plan with detailed finishing and installation methods.
 - f. Heat resistant cables are recommended for lighting installation.
 - g. All lightings shall be installed on pipe grid using light hanger. Pipe grid shall be installed with each grid within 1.5m.
- (v) RIC Content Development and Research (CDR) Office
- (aa) The Bidder shall propose required equipment including interior design.
 - (bb) Refer to the attached floor plan for detailed information.
- (vi) RIC Supporting Office
- (aa) Proposed portable stations shall accommodate 10 notebooks with charging function.
- (vii) RIC Multimedia Classroom
- (aa) The Bidder shall propose required equipment including interior design.
 - (bb) Refer to the attached floor plan for detailed information.
 - (cc) The Bidder shall design and propose a plan to manage all the equipment of a classroom through a tablet.
 - (dd) The Bidder shall propose a DSP Mixer with built-in echo cancelling function for video conferencing.
 - (ee) Visual signal in a classroom shall be proposed with HD based system.
 - (ff) The Bidder shall propose furniture based on 1 table per 1 person.
- (viii) RIC General Classroom
- (aa) The Bidder shall propose required equipment including interior design.
 - (bb) Refer to the attached floor plan for detailed information.
 - (cc) The Bidder shall design and propose a plan to manage all the equipment of a classroom through a tablet.
 - (dd) The Bidder shall propose a DSP Mixer with built-in echo cancelling function.
 - (ee) The Bidder shall propose furniture based on 1 table per 2 people.

(ix) RIC Security System

- (aa) The Bidder shall review the attached the floor plan of RIC and propose locations of cameras, sensors to provide a security system.
- (bb) The Bidder shall propose an installation plan including cabling method and material of cables.

(c) Lab Schools

- (i) Proposed firewall S/W shall include anti-virus and child protection functions.
- (ii) Proposed 2 portable stations shall accommodate 10 notebooks for students, 1 notebook for a teacher, 1 projector and 1 printer, with charging function.
- (iii) Proposed UPS shall abide by electricity standards of Colombia.
- (iv) The Lab Schools shall be connected to Internet (Minimum speed: 2Mbps) and the connection cost to Internet (Satellite connection cost excluded) shall be borne by the Supplier for 1 year upon completion of acceptance test.

2.8 Role & Responsibilities of the Stakeholders

(a) General Requirement

- (i) The Supplier shall propose a role & responsibilities model on the basis of the requirements stated below.
- (ii) The Bidder may propose a plan that best serves the Purchaser's objectives of the Component. The Bidder shall present the point of change management clearly.

(b) Transportation /Delivery

Stakeholders	Role & Responsibility
MOE	<ul style="list-style-type: none"> • Confirm/approve the shipping list provided by the supplier. • Confirm the method and responsible subject of the pre-inspection before shipping.
Supplier	<ul style="list-style-type: none"> • Supply, delivery, installation, and test of all the hardware and software specified for NIC and 5RICs. • Prepare and submit "Transportation Plan" including the schedule, method, period and insurance prescription status to MOE. After MOE's approval, supplier shall begin to transport. • All expenses required for transportation

	(transportation (including inland transportation), insurance fee, etc) shall be paid by the Supplier.
--	---

(c) Installation

Stakeholders	Role & Responsibility
MOE	<ul style="list-style-type: none"> • Coordinate any conflicts between RIC and Supplier and define the works for each organization clearly. • Review and approve the “Installation Plan” and “Installation Complete Report” submitted by Supplier.
NIC	<ul style="list-style-type: none"> • Designate the storage place for H/W and S/W before installation and provide them to the supplier without any cost. • Secure engineers required for NIC operation before installation. • Utilize NIC engineers in installation allowing them to acquire the technology required for stable operation.
RIC	<ul style="list-style-type: none"> • Designate the storage place for the supplied H/W and S/W before installation and provide them to the supplier • Secure the infrastructure engineers required for RIC operation before installation. • Utilize RIC infrastructure engineer in installation allowing them to acquire the technology for stable operation in the future
Supplier	<ul style="list-style-type: none"> • Prepare and submit the “Installation Plan” including the apparatus list, installation schedule for each RIC, installation method and installation personnel to MOE before installation and get its approval before installation begins. • Install all apparatus, interior and cabling required for NIC/RIC establishment. • All expense required for installation shall be paid by the Supplier. • Supply and delivery of the all hardware and software and interior. • Submit reports (daily, weekly, monthly report) stipulated in the Contract during installation. • Submit the “Installation Complete Report” to MOE after installation is finished. • Provide installation service

(d) Acceptance Test

Stakeholders	Role & Responsibility
MOE	<ul style="list-style-type: none"> Review and approve the “Acceptance Test Plan” and “Acceptance Test Complete Report” provided by the supplier. Dispatch MOE staff to each RIC and monitor the test progress.
NIC	<ul style="list-style-type: none"> Utilize the engineer in acceptance test to help in its smooth progress. Operational Training Finalize the target persons for operational training before it begins.
RIC	<ul style="list-style-type: none"> Utilize the engineer in acceptance test to help in its smooth progress Submit the “Acceptance Test Complete Report” to MOE after the acceptance test is completed.
Supplier	<ul style="list-style-type: none"> Prepare and submit the “Acceptance Test Plan” including test method, schedule and target to MOE before the acceptance test begins and get approval from MOE. Prepare for smooth progress of acceptance test. The required expense shall be paid by the Supplier. Submit the “Acceptance Test Complete Report” to MOE after the acceptance test is completed.

(e) Operational Training

Stakeholders	Role & Responsibility
MOE	<ul style="list-style-type: none"> Review and approve the “Operational Training Plan” and “Operational Training Complete Report” provided by the supplier.
NIC	<ul style="list-style-type: none"> Finalize the target persons for operational training before operational training begins. Submit the “operational Training Complete Report” to MOE after the operational training is finished.
RIC	<ul style="list-style-type: none"> Finalize the target persons for operational training before operational training begins. Submit the “operational Training Complete Report” to MOE after the operational training is finished.
Supplier	<ul style="list-style-type: none"> Prepare and submit “Operational Training Plan” to MOE after acceptance test, and get its approval

	<p>to implement the operational training.</p> <ul style="list-style-type: none"> • Submit the “Operational Training Complete Report” to MOE after the operational training is completed. • Provide operational training service in Spanish
--	--

(f) Maintenance

Stakeholders	Role & Responsibility
MOE	<ul style="list-style-type: none"> • Confirm the beginning point for maintenance for each RIC/apparatus after discussing with the supplier. • Confirm and approve the documents including the maintenance method, schedule, target and period provided by the supplier. • Check the maintenance status for stable operation of each RIC after the project is completed.
NIC	<ul style="list-style-type: none"> • Utilize maintenance personnel
RIC	<ul style="list-style-type: none"> • Utilize maintenance personnel
Supplier	<ul style="list-style-type: none"> • Prepare and submit the “Maintenance Plan” for smooth operation of NIC/RIC after the installation is finished. • Provide maintenance service

2.9 Human Resource Requirement

(a) General Requirement

2.9

Human Resource Requirement (a) The Supplier shall propose a plan for human resources on the basis of the basic human resource requirements stated below and shall provide the certificates of experience. The bidder must deliver evidence that all the proposed personnel has given its consent to participate in the “ICT Education Capability Building in Colombia” Project. The Purchaser will reserve the right to verify the evidence. In case the consent was not given, the proposal shall be rejected.

General Requirement

(ii) The Bidder may propose a plan that best serves the Purchaser’s objectives of the Component. However, the Bidder shall prove each human resource’s capabilities in the specific field.

(iii) The Bidder may propose a team of human resources to perform the work specified below as performed by 1 person as long as the team’s performance is guaranteed and it meets the duration requirement below. The Bidder may propose a greater number of people to perform the work, but never less than those indicated below.

The Supplier shall propose a plan for human resources on the basis of the basic human resource requirements stated below.

(b) Installation

(i) Required human resource for the e-Portal H/W and S/W installation

	Field of expertise	No of staff required	Duration	Requirement
Supplier (Korean experts) - Installation	Server Engineer (Expert)	1	2 month	- 10 years experience of server installation - 3 project experience of server installation and implementation - Bachelor degree
	Server Engineer (Advanced)	2	1 month	- 5 years experience of server installation - 3 project experience of server installation and implementation - Bachelor degree
	DB Engineer	1	1 month	- 5 years experience of DB installation - 3 project experience of DB installation, implementation and management - Bachelor degree
	Network Engineer	1	1 month	- 5 years experience of network equipment installation - 3 project experience of network installation and implementation - Bachelor degree

(ii) Required human resource for the NIC Operation Office installation

	Field of expertise	No of staff required	Duration	Requirement
Supplier - Installation	System Engineer	1	1 week	- Knowledge and Installation experience in computer system
	Network Engineer	1	1 week	- Knowledge and Installation experience in network system

	Electric Engineer	2	1 week	- Knowledge and Installation experience in electric system
--	-------------------	---	--------	--

* The table above for the NIC Operation Office experts is recommendation only. The Bidder may propose a plan to establish the NIC Operation office with appropriate number of experts.

(iii) Required human resource for the each RIC H/W and S/W installation(except Multimedia Studio)

	Field of expertise	No of staff required	Duration	Requirement
Supplier (Korean experts) - Installation	System Engineer	1	2 month	- 5 years experience of system installation - 3 project experience of H/W and S/W installation and implementation - Bachelor degree
Supplier (Colombian experts) - Installation	System Engineer	2	2 month	- Knowledge and Installation experience in equipment installation
	Network Engineer	2	1 month	- Knowledge and Installation experience in network system
	Electric Engineer	2	1 month	- Knowledge and Installation experience in electric system
	Audio/Visual System Engineer	3	1 month	- Knowledge and Installation experience in audio/video system

(iv) Required human resource for the each Multimedia Studio construction

	Field of expertise	No of staff required	Duration	Requirement
Supplier (Korean experts) - Equipment Installation	Studio Engineer	1	3 month	- 10 years experience - 5 project of studio construction management
	Audio Engineer	1	2 month	- 5 years experience - 3 project of studio

				equipment installation
	Video Engineer	1	2 month	- 5 years experience - 3 project of studio equipment installation
	Training Engineer	1	1 month	- 5 years experience - 3 project of studio equipment installation
Supplier (Korean experts) - Soundproof Interior	Sound Engineer	1	2 month	- 10 years experience - 3 project of studio soundproof interior
	Construction Engineer	2	2 month	- 5 years experience - 3 project of studio construction
	Special Lighting Engineer	1	1 month	- 5 years experience - 3 project of studio lighting system installation

* Supplier - Equipment Installation	Audio Engineer	4	2 month	- Knowledge and Installation experience in audio system
	Video Engineer	6	2 month	- Knowledge and Installation experience in video system
* Supplier - Soundproof Interior	Construction Engineer	12	2 month	- Knowledge and Installation experience in construction
	Special Lighting Engineer	6	1 month	- Knowledge and Installation experience in lighting & electrical system

* The table above for the Multimedia studio experts is recommendation only. The Bidder may propose a plan to establish the multimedia studio with appropriate number of experts.

(v) Required human resource for the each RIC Security System installation

	Field of expertise	No of staff required	Duration	Requirement
Supplier (Colombian experts)	System Engineer	1	1 week	- Knowledge and Installation experience in security system

- Installation	CCTV Engineer	2	1 Week	- Knowledge and Installation experience in security system
	Electric Engineer	2	1 week	- Knowledge and Installation experience in security system

(vi) Required human resource for the Lab School installation

	Field of expertise	No of staff required	Durati on	Requirement
Supplier (Colombian experts) - Installation	Master Engineer	5	3 month	- Knowledge and Installation experience in computer system
	Bachelor Engineer	10	3 month	- Knowledge and Installation experience in network and computer system

3 e-Portal

3.1 Objective of the Component

The e-Portal development has the following objectives;

- (a) To provide a scenario for the creation of networks and communities of learning based on web 2.0, 3.0 and later, which foster research and innovation through virtual scenarios for the learning community.
- (b) To provide courseware and different types of high quality Learning Content to be accessed by educational community, with the purpose of generating knowledge from multiple perspectives, formats and tools, that answer to their needs and interests.
- (c) To improve e-Portal services through the use of solutions based on flexible and scalable technologies to optimize usability and allow a better user experience.
- (d) To provide mechanisms that allow knowing trends, likes, interests, statistics of use to permanently evaluate the services and products offered to community, so decisions can be taken on a proper way and be reflected on e-Portal operation and Policies.
- (e) To define a sustainability plan to the effective operation and revitalization of Content and Services offered by Colombia Aprende.
- (f) To enhance the quality of teachers with the virtual teacher training system.

3.2 Conceptual design of the Component

To accomplish the objectives of the Project, this component is designed to enhance the services and content offered by Colombia Aprende, www.colombiaprende.edu.co, this way, National and International learning community recognize it as a referent on which they can access to informative services, learning content, virtual teacher training processes, interaction services, access to help desk, content developed through this project, as well as virtual communities that can be established around this offer.

e-Portal shall serve 6 target user groups defined in 3.4 through the central operation by NIC.

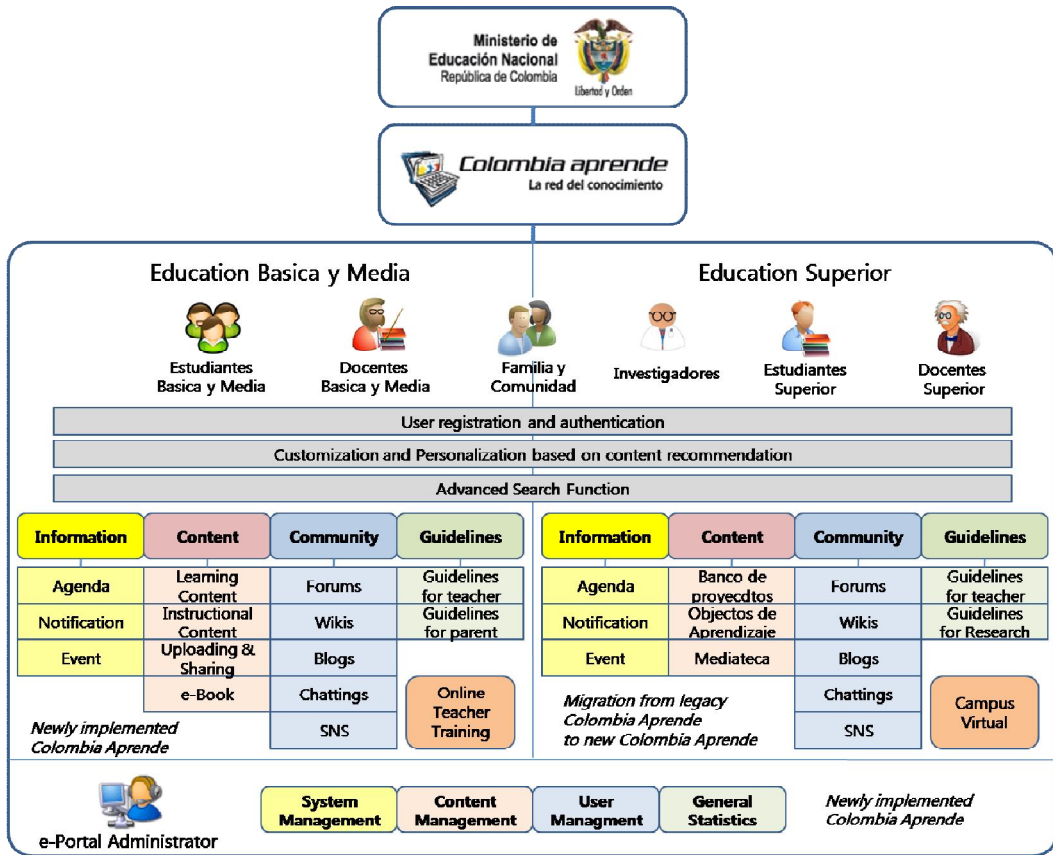

The following figure shows the architecture of e-Portal H/W and S/W.

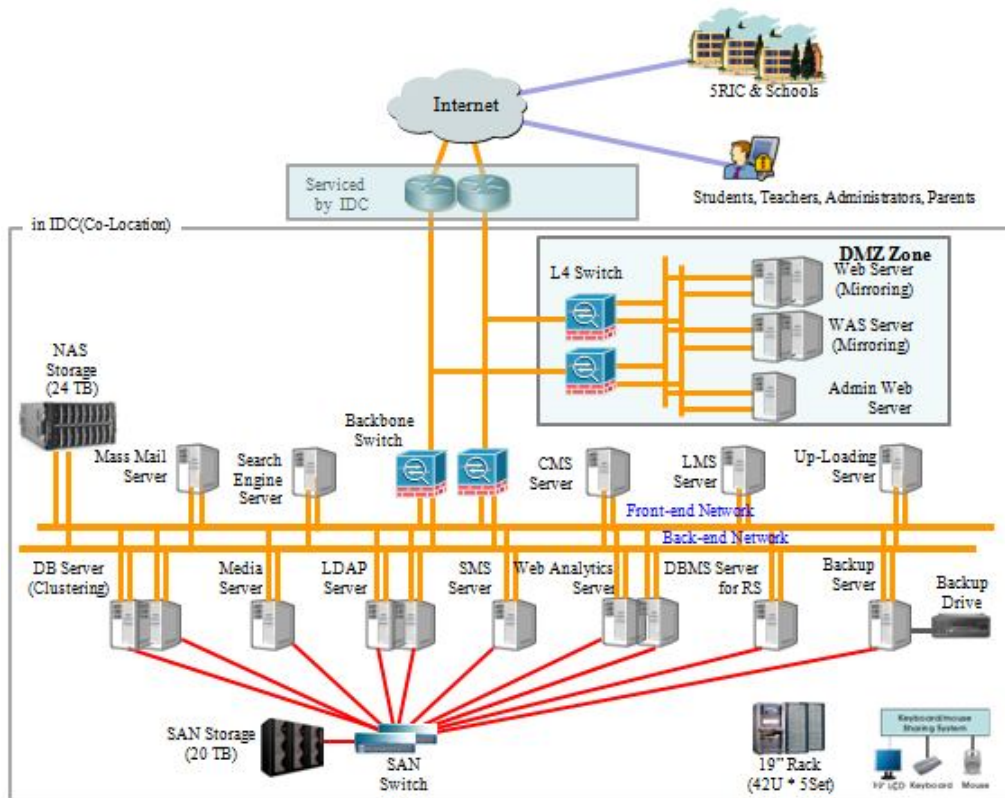

The following figure shows the architecture of e-Portal service system.

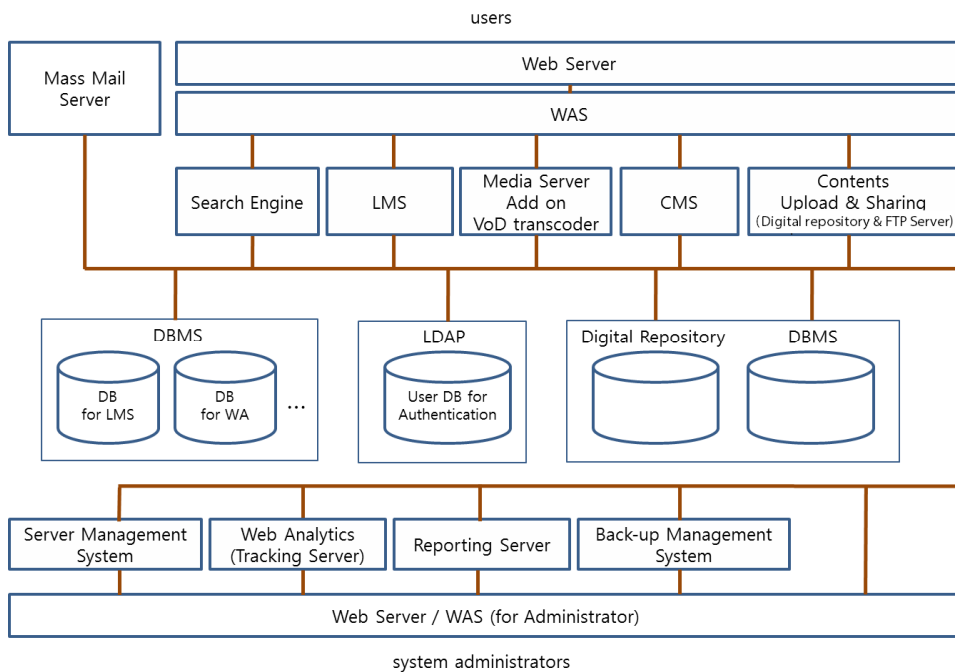

3.3 Definitions

(a) e-Portal

Colombia Aprende is the main point of access and interaction of the Colombian learning community, through the offer and fostering of use of learning content and virtual educational services.

3.4 Target user groups

e-Portal may serve, but not limited to, six-target user groups. Service functions are to be implemented according to the target user groups.

- (a) User registration and authentication function, customization and personalization function, search function, content recommendation function and general information service are to be provided for all users.
- (b) Learning content, e-book service, Web 2.0 tools, and Community service based on Social Network Service such as Facebook are to be provided for elementary, middle, and high school students.
- (c) Instructional content, content upload and sharing functions, community service based on SNS, guidelines for teachers, and Web 2.0 Tools such as blogs are to be provided for elementary, middle, and high school teachers.
- (d) School information service (school locations, telephone numbers, etc), guidelines for parents, and Web 2.0 tools such as Forums are to be provided for family and community users.
- (e) General portal statistics, web content management function, and the function to monitor activities of authenticated users are to be provided for web masters.
- (f) e-portal framework is to be provided for the target user groups including those of higher education. The legacy data of higher education is to be migrated from old Colombia Aprende to the new framework for higher education through the Project.

Target user group	Service modules
All users	<ul style="list-style-type: none"> • User registration and authentication • Customization and personalization based on content recommendation • Search function • General Information such as Notifications, Agenda, Events

Elementary, Middle, and High school students	<ul style="list-style-type: none"> • Learning content • e-book service • Community service based on SNS • Web 2.0 Tools: Blogs, Wikis, Forums, Chattings
Elementary, Middle, and High school teachers	<ul style="list-style-type: none"> • Instruction content • e-book service • Content upload and sharing • Web 2.0 Tools: Blogs, Wikis, Forums, Chattings • Community service based on SNS • Guidelines for teachers • Virtual teacher training
Family and Community	<ul style="list-style-type: none"> • Forums • School Information Service (Location, telephone number, etc) • Parents Web 2.0 • Guidelines for parents • Access to service for search school "buscando colegio" • http://www.mineducacion.gov.co/buscandocolegio/ • Access to service for search careers or academic programs. "Buscando carrera" • http://www.colombiaaprende.edu.co/html/estudiantesuperior/1608/propertyvalue-40000.html
Researchers	<ul style="list-style-type: none"> • Migration from legacy Colombia Aprende to new e-portal
College and University students	<ul style="list-style-type: none"> • Migration from legacy Colombia Aprende to new e-portal
College and University Instructors	<ul style="list-style-type: none"> • Migration from legacy Colombia Aprende to new e-portal
Web Masters	<ul style="list-style-type: none"> • Monitoring activity of authenticated users • Portal general statistics • Web content management • Mass mailing to users

3.5 **Deliverables:** The following deliverables are the minimum quantities and technical specifications required for all bidders. In case these minimum quantities and technical specifications are not satisfied, it will be considered non-responsive of a subcomponent and zero point will be given for the subcomponent where the understated mandatory requirements are not met (for example, unsatisfied e-Portal server -> zero point for NIC e-Portal Hardware). The bidder shall provide adequate supporting information that the deliverables proposed by the bidder is fully compliant with the requirements. Insufficient or incomplete information and any omission of supporting information may result in non-responsive of a subcomponent. The Bidder shall provide all the information to prove that the proposed deliverables meet the technical specifications specified below. The detailed specification on the attachments the Purchaser has provided separately include the requirements below and the other requirements that are also required and will be evaluated but will not be considered non-responsive even if some of the requirements not mentioned as the mandatory requirements specified below are not met. However, the bidder shall acknowledge that the compliance rate of the deliverables will have a great effect on the technical evaluation. In addition, the Successful Bidder shall remedy all the unsatisfied requirements for signing the contract with the Purchaser. In case of failure of remedying all the unsatisfied requirements, its bid shall be rejected and the Purchaser shall continue the negotiation with the next lowest evaluated Bidder.

Fulfillment of minimum technical specifications shall be explicitly stated on both the proposal and supporting documents. Any omission or insufficient/vague/improper statement of the minimum technical specifications on the proposal may result in either deduction of points or no point for that particular sub component (type of processor, model number and other details shall be specified).

In addition, all pages in the proposal, including the brochures and annex, must be numbered, both on original and copies. These deliverables must be presented in a table that has the following elements: Requirement, Proposal, Page number(s) for the brochure(s), Requirements not fulfilled, and Added Value.

(a) Hardware

No	Equipment	Specification	Unit	Q'ty
----	-----------	---------------	------	------

1	Web Server for users and administrator	<ul style="list-style-type: none"> • 4 Core Intel Xeon 2.4GHz/10MB L3 Cache * 2EA • 16GB MEM • 300GB HDD * 2EA • 8GB FC HBA * 2EA • Dual Power Supply 	Set	3
2	WAS Server	<ul style="list-style-type: none"> • 4 Core Intel Xeon 2.4GHz/10MB L3 Cache * 2EA • 16GB MEM • 300GB HDD * 2EA • 8GB FC HBA * 2EA • Dual Power Supply 	Set	2
3	LMS Server	<ul style="list-style-type: none"> • 4 Core Intel Xeon 2.4GHz/10MB L3 Cache * 2EA • 8GB MEM • 300GB HDD * 2EA • 8GB FC HBA * 2EA • Dual Power Supply 	Set	1
4	DB Server	<ul style="list-style-type: none"> • 8 Core Intel Xeon 2.13GHz/24MB L3 Cache * 4EA • 32GB MEM • 300GB HDD * 2EA • 8GB FC HBA * 2EA • Dual Power Supply 	Set	2
5	LDAP Server	<ul style="list-style-type: none"> • 4 Core Intel Xeon 2.4GHz/10MB L3 Cache * 2EA • 8GB MEM • 300GB HDD * 2EA • 8GB FC HBA * 2EA • Dual Power Supply 	Set	2
6	Content and Uploading Server	<ul style="list-style-type: none"> • 4 Core Intel Xeon 2.4GHz/10MB L3 Cache * 2EA • 8GB MEM • 300GB HDD * 2EA • 8GB FC HBA * 2EA 	Set	1

		<ul style="list-style-type: none"> • Dual Power Supply 		
7	Search Engine Server	<ul style="list-style-type: none"> • 4 Core Intel Xeon 2.4GHz/10MB L3 Cache * 2EA • 8GB MEM • 300GB HDD * 2EA • 8GB FC HBA * 2EA • Dual Power Supply 	Set	1
8	CMS Server	<ul style="list-style-type: none"> • 4 Core Intel Xeon 2.4GHz/10MB L3 Cache * 2EA • 8GB MEM • 300GB HDD * 2EA • 8GB FC HBA * 2EA • Dual Power Supply 	Set	1
9	Media Server with VoD Transcoding	<ul style="list-style-type: none"> • 4 Core Intel Xeon 2.4GHz/10MB L3 Cache * 2EA • 16GB MEM • 300GB HDD * 2EA • 8GB FC HBA * 2EA • Dual Power Supply 	Set	1
10	SMS Server	<ul style="list-style-type: none"> • 4 Core Intel Xeon 2.4GHz/10MB L3 Cache * 2EA • 8GB MEM • 300GB HDD * 2EA • 8GB FC HBA * 2EA • Dual Power Supply 	Set	1
11	DBMS Server for Digital Repository System	<ul style="list-style-type: none"> • 4 Core Intel Xeon 2.4GHz/10MB L3 Cache * 2EA • 8GB MEM • 300GB HDD * 2EA • 8GB FC HBA * 2EA • Dual Power Supply 	Set	1
12	Web Analytics & Reporting system	<ul style="list-style-type: none"> • 4 Core Intel Xeon 2.4GHz/10MB L3 Cache * 2EA 	Set	2

		<ul style="list-style-type: none"> • 8GB MEM • 300GB HDD * 2EA • 8GB FC HBA * 2EA • Dual Power Supply 		
13	Backup Server	<ul style="list-style-type: none"> • 4 Core Intel Xeon 2.4GHz/10MB L3 Cache * 2EA • 8GB MEM • 300GB HDD * 2EA • 8GB FC HBA * 2EA • Dual Power Supply 	Set	1
14	Backup Device	<ul style="list-style-type: none"> • Backup methods LTO 5 • Drives: 4 EA • Slot: 48 or more <p>Including Cartridge 50Pack</p>	Set	1
15	Mass Mail Server	<ul style="list-style-type: none"> • Processor: Intel core i5-2400 processor (3.10 GHZ,6MB) and above • Memory: 6GB • HDD: 1TB • Monitor: 22" LCD Monitor 	Set	1
16	SAN Switch	<ul style="list-style-type: none"> • Ports: 24 EA or more (Including SFP) • Link speed: 8,4,2.1 Gbps auto- sensing 	Set	2
17	SAN Storage	<ul style="list-style-type: none"> • Host Interface: 8Gbps FC 8 port, 1Gbps iSCSI 4 port • Capacity : usable 20TB <p>The major components (Power, Fan, Controller, etc.) redundancy</p>	Set	1
18	NAS Storage	<ul style="list-style-type: none"> • NAS interface 1Gbps 4 port, 10Gbps 4 ports • Capacity : usable 24TB <p>The major components (Power, Fan, Controller, etc.) redundancy</p>	Set	1

19	Monitoring PC	<ul style="list-style-type: none"> • Processor: Intel core i5-2400 processor (3.10 GHZ,6MB) and above • Memory: 6GB • HDD: 1TB • Monitor: 22" LCD Monitor 	Set	1
20	L4 Switch	<ul style="list-style-type: none"> • Layer 4~7 Switching • Backplane: 16Gbps or more • 1G Fiber Ethernet: 8ports or more <p>Including SFP Cable</p>	Set	2
21	Backbone Switch	<ul style="list-style-type: none"> • Backplane: 720Gbps or more • 10G Ethernet: 16ports or more • 1G Fiber Ethernet: 24ports or more • 10/100/1000 Mbps Ethernet: 48ports or more • Dual Power Supply <p>Including SFP Cable</p>	Set	2
22	Workgroup Switch	<ul style="list-style-type: none"> • 1G Fiber Ethernet: 4ports or more • 10/100/1000 Mbps Ethernet: 24ports or more 	Set	2
23	RACK	<ul style="list-style-type: none"> • 42U Rack, PDU • Only one(1) rack for KVM Switch and Panel Monitor 	Set	5
24	Cable & Accessory for installation	<ul style="list-style-type: none"> • Including cable & accessory for equipment installation 	Set	1

(b) Software Solution

No	SW Solution	Unit	Q'ty
1	Linux Operating System	Set	17
2	<i>Windows Operating System</i>	Set	2
3	<i>Windows 7 or 8 Operating System (64-bit, Ultimate Edition)</i>	Set	1
4	Web Server	Set	3

5	Web Application Server	Core	24
6	DBMS	Core	64
7	LDAP	Set	2
8	Search Engine	Set	1
9	<i>Content Management System</i>	Set	1
10	<i>Learning Management System</i>	Set	1
11	<i>Digital Repository System</i>	Set	6
12	<i>DBMS For Digital Repository System</i>	Set	6
13	<i>Media Server</i>	Set	2
	<i>VoD Transcoder</i>	Ch.	2
	<i>Network DVR</i>	Set	2
14	<i>Server Management System</i>	Set	1
15	<i>Web Analytics</i>	Set	1
	<i>Reporting Server for Web Analytics</i>	Set	1
16	FTP Server	Set	1
17	Office to PDF Auto Converter	Set	1
18	<i>Grid Solution</i>	Set	1
19	<i>Back-Up Server</i>	Set	1
20	<i>Portal framework</i>	Set	1
	<i>UI framework</i>	Set	1
21	<i>Translation service for e-Portal</i>	Set	1
22	<i>Bulk Email Newsletter Software</i>	Set	1

(c) Others

No	Documentations	Unit	Q'ty
1	Graphic Style Manual (User-friendly)	Set	1
2	Operation Manuals of the E-Portal (CMS; LMS; Repository)	Set	3
3	Style guideline for E-portal	Set	1
4	E-portal benchmarking Complete Report	Set	1
5	Analysis and design for new e-portal report	Set	1
6	Awareness Plan	Set	1

3.6 General Requirements

- (a) The Purchaser seeks to enhance Colombia Aprende, current e-Portal managed by the Ministry of Education of Colombia to meet international standards and to accommodate more users and user groups.

- (b) The Bidder shall propose a plan to develop the Deliverables specified above that best serves the Purchaser's objectives. The configuration diagram of the proposed system with goals and functions shall be clearly stated in a proposed plan.
- (c) e-Portal H/W and S/W for Colombia Aprende are to be installed at an IDC later designated by the Ministry of Education of Colombia (near Bogota).
- (d) The Bidder shall propose H/W and S/W compatible with those currently operated by the Ministry of Education of Colombia in Colombia.
- (e) To ensure compatibility between NIC and RIC system in the future, the proposed system shall guarantee safety, compatibility and expandability.
- (f) The Bidder shall propose a plan to increase the awareness of e-Portal by teachers and students. This plan shall include activities, roles and responsibilities for the MOE, estimate budget, frequency and target.
- (g) e-Portal shall be implemented with Spanish language used in Colombia. Operating systems and keyboards provided shall support Spanish as well.
- (h) e-Portal shall provide cross-browsing functions (interoperable with general web browsers such as Internet Explorer, Safari, Chrome and Firefox).
- (i) The Supplier shall not infringe any intellectual property rights of others for any content including images and multimedia resources utilized for e-Portal. The Purchaser shall not be liable for any infringement.
- (j) The Purchaser shall acquire all exclusive rights, including all transferable intellectual property rights (IPR) and use rights, in the deliverables, including their specification, algorithms, architectural approach and technical solution and specifically all rights in software, sources and comments as contained therein. Such rights shall include the absolute right to develop, modify or have modified such software.
- (k) There shall be no license fees, once the e-Portal is handed over to the Purchaser.
- (l) There shall be no limits on the number of users that can use e-Portal.
- (m) The Supplier shall bear all responsibility to take any necessary security measures against any hacking threats during the Project.
- (n) The source code for e-Portal shall be supplied except the source code for commercial packaged solutions.

3.7 Technical Requirements

The Bidder shall propose H/W and S/W on the basis of the following

information.

(a) Overall H/W & S/W

- (i) The Bidder shall carefully analyze the configurations of H/W, S/W and network system required in RFP and design an open architecture system.
- (ii) The system shall be proposed as SMP (Symmetric-Multi-Processing).
- (iii) The proposed server system shall consider the speed and reliability of the storage device and establish a fiber channel based SAN (Storage Area Network) including SAN storage (20TB-effective).
- (iv) The server system shall be designed to avoid service interruption including the automatic management function.
- (v) The proposed server system shall monitor the presence of abnormality in the system and shall be established to maximize the reliability of the system.
- (vi) The proposed server system shall support Hot-Swap and Plug functions in order to provide uninterrupted service when problem occurs at the disk.
- (vii) The power for the proposed server and storage shall have duplex configuration and have hot-swap function.
- (viii) The configuration shall allow the monitoring of performance, capacity, configuration and disturbance of the server resources (CPU, Cache, Memory, Disk) on a real time basis in GUI environment.
- (ix) The network interface card and HBA card of each server shall have duplex configuration and include automatic disturbance transference function.
- (x) The proposed system shall support the back-up channel mode (fail over) and load balancing functions in preparation for the disturbance at I/O channels between server and storage as well as provide the S/W required for duplex configuration (Active-Active).
- (xi) To provide smooth e-Portal service, the proposed system shall have sufficient network broadband and be able to spread out the network loads, which are temporarily concentrated.
- (xii) The proposed commercial S/W shall be authentic products. If they are open sources, they should be free from any technical, legal or administrative restrictions.
- (xiii) All proposed S/W shall be authentic and latest. For each product,

license is provided. They shall not infringe any copyrights.

- (b) Web Server
 - (i) Support HTTP/1.1 (RFC2616)
 - (ii) Be Operational on any Linux operating system
 - (iii) Support relational databases for LDAP authentication
 - (iv) Include Multiple Directory Index directive functions
 - (v) Include Unlimited flexible URL rewriting and aliasing functions
 - (vi) Include Content negotiation functions
 - (vii) Include Virtual Host functions
 - (viii) Include Configurable Reliable Piped Logs functions
- (c) Web Application Server
 - (i) Support J2EE 1.4 certification and JavaEE5 certification
 - (ii) Support EJB 3.0
 - (iii) Support incorporation with both JSF2.1 and JSP engine
 - (iv) Support Web Service Metadata (WSM)
 - (v) Support Web Server monitoring environment(Desirable)
- (d) DBMS
 - (i) Be operational under Window Server 2008R2 OS
 - (ii) Support ANSI SQL
 - (iii) Support Core DB Operations
 - (iv) Comply with ACID
 - (v) Support online backup
 - (vi) Support Reporting functions
 - (vii) Support Auto-tuning functions
 - (viii) Support Analysis and OLAP functions
 - (ix) Support high-availability functions
- (e) LDAP Server
 - (i) Be operational under Linux OS Platform environment
 - (ii) Support Lightweight Directory Access Protocol (v3)
 - (iii) Support access to X.500 directory service

- (f) Search Engine
 - (i) Supports Linux OS platform
 - (ii) Support functions of data indexing and update of shared memory composed of number information (date, field limit code, etc.)
 - (iii) Support functions of applying to weight application by fields and controlling ranking rules
 - (iv) Support for arranging Spanish and multiple languages in high speed
 - (v) Support functions to arrange category by groups and count it
 - (vi) Support Unicode (UTF-8)
 - (vii) Support Morphological analyzer of Spanish
 - (viii) Support dictionary (system dic / user dic / pre-analysis dic / stemming dic) edition and building tools
- (g) Content Management System
 - (i) Be operational under Linux OS platform
 - (ii) Support functions to generate general standard printing template that can be automatically applied for current and new content
 - (iii) Support access control functions by user groups to control access to web pages by authorized users
 - (iv) Support life cycle management functions to manage overall life cycle of content from creation, revisions, publication and archiving to discard of content
 - (v) Support content virtualization functions for administrators to work with virtual copy of the entire web site.
 - (vi) Support functions to support multi-language user interface including Spanish
 - (vii) Support version management functions
- (h) Learning Management System
 - (i) Be operational under Linux OS Platform
 - (ii) Support functions to work with RDBMS such as Microsoft SQL Server, MySQL, PostgreSQL
 - (iii) Support registration by IMS Enterprise and other standard methods
 - (iv) Support IMS QTI, XML and XHTML formats for quiz questions (Support import and export functions)

- (v) Support management functions through IMS Content Packaging, SCORM, AICC (CBT), LAMS standards
- (vi) Support integration with Drupal, Joomla or 3rd party CMS
- (i) Digital Repository System
 - (i) Support digital resource storage system to store digital asset resources with related metadata
 - (ii) Support interface for administration, deposit, ingest, search and access
 - (iii) Support both “JSPUI using JSP” and “Java Servlet API & XMLUP”
 - (iv) Support web interface as a default and support OAI-PMH 2.0
 - (v) Support functions to export METS(Metadata Encoding and Transmission Standard) package
 - (vi) Support common interoperability standards to use institutional repository domain such as Open Archives Initiative Protocol for Metadata Harvesting, SWORD, OpenSearch, RSS
 - (vii) Support Dublin Core (simple and qualified) and LOM metadata.
 - (viii) Support relational DB
 - (ix) Support both CMS and LMS in the manner that the digital repository system contains all the content or data to be searched, accessed and retrieved by both CMS and LMS
 - (x) Support metadata harvesting as below

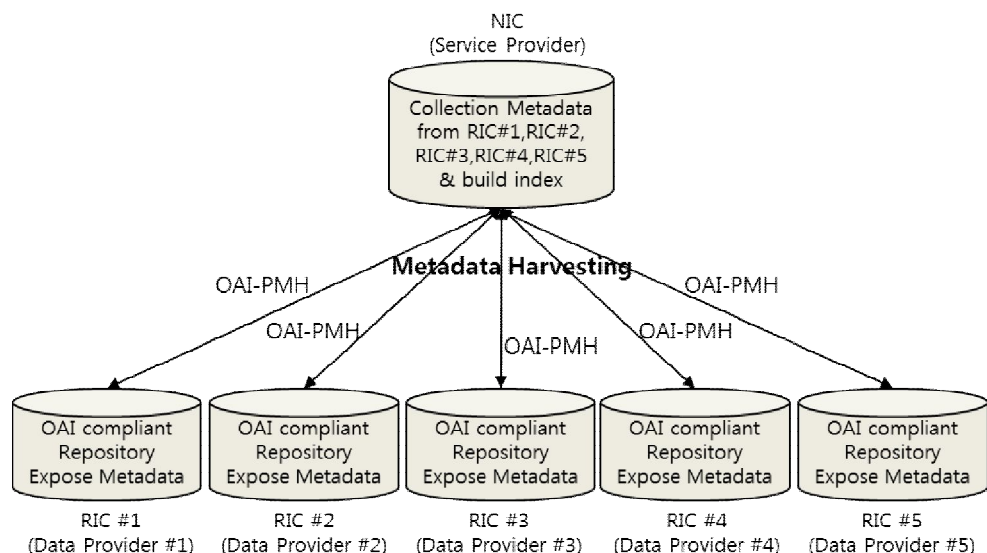

- (j) DBMS For Digital Repository System

- (i) Be operational under Linux Operating System
 - (ii) Support ANSI SQL
 - (iii) Comply with ACID
- (k) Media Server with VoD Transcoder and Network DVR
- (i) Be operational under Linux OS Platform
 - (ii) Support up to 10Gbps per-server performance
 - (iii) Support Video Streaming (live and on-demand)
 - (iv) Support Audio Streaming (live and on-demand)
 - (v) Support Multi-Protocol, Multi-Client Streaming
 - (aa) Flash (RTMP, RTMPT, RTMPS, RTMPE, RTMPTE)
 - (bb) iPhone/iPad (HTTP Streaming)
 - (cc) Silverlight (Smooth Streaming)
 - (dd) QuickTime/3Gpp (RTSP/RTP)
 - (ee) IPTV (MPEG-TS)
 - (vi) Support VoD Transcoder with the following encoding and decoding characteristics:
 - (aa) Decoding: Video (MPEG2, MPEG4 Part2, H.264/AVC), Audio (MP3, AAC, MPEG1 Part1/2, Speex, G.711)
 - (bb) Encoding: Video (H.264/AVC), Audio (AAC(LC & HE))
- (l) Server Management System
- (i) Be operational under Linux OS Platform
 - (ii) Be a Single Integrated Product
 - (iii) Support open source CMDB as a single repository to manage IT resources
 - (iv) Support the following monitoring functions
 - (aa) ICMP response testing
 - (bb) SNMP response testing
 - (cc) Standard TCP/IP services testing
 - (dd) Windows/Linux service availability testing
 - (ee) Windows/Linux process availability testing
 - (v) Support the following Performance Monitoring functions

- (aa) Scheduled collection and storage of SNMP OID values
 - (bb) Agentless native JMX performance monitoring of J2EE servers
 - (cc) Pre-loaded MIBs and new local MIBs
- (vi) Support Event Management, Log Monitoring & Altering functions
- (vii) Support Web-based console/dashboard
- (m) Web Analytics and Reporting System
 - (i) Be operational under Linux OS Platform
 - (ii) Support functions to general and analyze web usage statistics through Script Embedding based Data Collection. However, the script shall be asynchronous not to affect the loading speed of the site and the average streaming loading speed shall be within 60ms
 - (iii) Support hierarchy classification and filtering of 80 or more analysis dimension, 130 or more general measurement index and multidimensional segmentation.
 - (iv) Support extension of user classification report with the combination of Dimension-Index-Segmentation-Filter
 - (v) Support auto mailing service
- (n) FTP Server
 - (i) Support Linux OS platform
 - (ii) Support LDAP authentication and SQL authentication
 - (iii) Support protocols for FTP, FTPS, SFTP, SCP, HTTP, HTTPS, WebDAV and WebDAV over SSL
 - (iv) Support SSH Tunneling and HTTP(S) Tunneling
 - (v) Support GUI remote administration
 - (vi) Support functions for Events/Alerts
 - (vii) Support functions for Protocol Conversion (incoming FTP/FTPS/SFTP/HTTP/HTTPS protocols converted to a back end FTP/SFTP server)
- (o) Office to PDF Auto Converter
 - (i) Support automatic conversion from MS Office document to PDF format document
- (p) Grid Solution

- (i) Support Java Applet
- (q) Back-up Server
 - (i) Support Spanish-based GUI to configure and manage all functions as a single platform
 - (ii) Monitor all process of each task in real-time
 - (iii) Support user-friendly interface to manage several rules to retrieve various and complex data
 - (iv) Support various backup functions such as deletion of repetitions, inline copy, relay, multiplexing, dispersion index, etc
 - (v) Provide alert functions to alter administrator in case of user defined events
 - (vi) Support Full Back-up, Incremental Back-up, Differential Back-up and Synthetic Full Back-up
- (r) Portal Framework and User Interface Framework
 - (i) Support WSRP/JSR 168 standards
 - (ii) Support WEB 2.0, AJAX, JSF and real-time test with debugging for UI Framework
- (s) Mass Mail Server
 - (i) Be operational under Windows 7 or 8 platform
 - (ii) Over 90 HTML email marketing templates included
 - (iii) Auto responder to send automatic email marketing drip campaigns
 - (iv) Bypass external SMTP mail servers with Direct Sending
 - (v) 256 simultaneous delivery connections for fast sending
 - (vi) Easy double opt-in email collection and subscription management
 - (vii) Automatic unsubscribe, opt-out and bounce processing
 - (viii) An entire year of open and click-through tracking with Group Metrics
 - (ix) Create unlimited customer surveys and collect unlimited responses
 - (x) Real-time campaign reporting down to specific email address activity
 - (xi) Login permission for your clients to see their email tracking reports

- (xii) Schedule email marketing campaigns to send and recur later
- (xiii) Easy to read survey response reports with charts and graphs
- (xiv) Install in English, Spanish
- (xv) No recurring fees
- (xvi) Unlimited email sending capability

3.8 Functional Requirements

The Bidder shall propose a solution on the basis of the following information;

(a) e-Portal H/W Functional Requirements

- (i) Web Server (mirroring), WAS Server (mirroring), DB Server (Clustering, active-active), LDAP Server (mirroring) shall have duplex configuration.
- (ii) The duplex server system for high availability shall be configured in a way that the resource allocation and collection among partitions (CPU or Core) is possible in order to maximize the server resource.
- (iii) All of the duplex server systems for high availability shall be separated into 2 physical systems in their configurations and proposed in a way that their specification, performance, operating system and S/W version are established equivalently.
- (iv) To ensure the stability of system files such as OS and system S/W, the internal disk of all servers shall be configured as mirroring.
- (v) The storage shall be configured in a way that it can allow the volume up and down while online and create different volumes into one file system.
- (vi) The data area of storage shall be configured in a way that it can ensure continuity of service at the single storage disturbance point.
- (vii) The storage back-up area shall be configured using internal copying solution and file copying solution.
- (viii) To ensure compatibility between different types of network devices, The Bidder shall propose products that comply with international standards.
- (ix) The connection between major networks and major servers shall handle large capacity traffic.
- (x) The proposed system shall provide real-time collection of system

operation log, security log and network log with monitoring functions.

- (xi) The proposed system shall be configured for backup and recovery through AP server, DB server and SAN switch.
- (xii) The proposed system shall support OS based backup and recovery for efficient OS backup.
- (xiii) Storage shall be configured to increase/decrease/expand the volume and to generate one file system with systems of different volumes.

(b) User Registration and Authentication

- (i) User registration and authentication functions shall be provided for only users with proper authentication to access restricted information. General information and some contents in all the E-Portal as notices, some videos and audios, shall be open to any users without authentication.
- (ii) User registration function shall be provided through a registration page for users to register ID and Password.
- (iii) User Agreement shall be provided for registration and only agreed users shall be able to register.
- (iv) Account (ID) shall be identical and no same account shall be issued.
- (v) In case the Purchaser wants to utilize identification number of Colombia (similar to the registration number of Korea), such identification number shall be checked and any overlapping accounts shall be automatically blocked from registration.
- (vi) Upon registration, users shall be able to select their user groups.
- (vii) User groups shall be categorized by age and by participating groups such as students, teachers, parents, administrators, etc.
- (viii) Services shall be personalized for each user group. User groups shall access to the information that is relevant and authorized for each user group.
- (ix) LDAP server shall be utilized to manage the database of user authentication.
- (x) Users shall be able to withdraw from e-Portal and withdrawal menu shall be accessible by general users.

(c) Customization and Personalization

- (i) Authenticated users shall be able to customize the service upon their interests.

- (ii) Personalized service shall be utilized for authenticated users. Content recommended by web master or content peer groups have viewed frequently shall be provided for users to personalize the service.
 - (iii) Configuration menu shall be provided to users to customize and personalize the service.
- (d) Content Upload and Sharing
- (i) Content upload functions shall be divided into two main user groups; general user groups (teachers and students) and administrators.
 - (ii) Depending on authentication and login policy, content provided to users shall be differentiated.
 - (iii) Content upload by general users
 - (aa) Content upload by general users shall be user friendly with easy-to-use input screen of metadata, intellectual property related information, category info. Content to be uploaded shall be attached through attachment function on the same screen.

There shall be included and considered, among others:

- Editing and updating functions
 - Content representation and visualization functions
 - Advanced search functions
 - Statistics and reports functions
 - Metadata logs import and export functions
 - Publishing management
- (bb) Content to be uploaded by general users shall be stored in the temporary repository. Only content reviewed and approved by the authorized e-Portal administrator upon approval of the Quality Control Team shall be transferred to the service repository system. Content shall be serviced through CMS.
 - (cc) File size of the content to be uploaded by general users shall be restricted under 10MB.
 - (dd) Content upload by general users shall utilize FTP or HTTP protocol.
- (iv) Content upload by Administrators
- (aa) Content upload by administrators between NIC and RIC shall utilize the OAI-PMH/SWORD/WebDAV protocol.
 - (bb) Content uploaded by RIC administrators to NIC shall be

user friendly with input screen of metadata, intellectual property related information, category info. Content to be uploaded shall be attached through attachment function on the same screen.

There shall be included and considered, among others:

- Editing and updating functions
- Content representation and visualization functions
- Advanced search functions
- Statistics and reports functions
- Metadata logs import and export functions
- Publishing management

(cc) Content uploaded by RIC administrators shall be directly stored in the NIC repository system and content shall be serviced through CMS by web masters of e-Portal.

(e) Streaming Service

- (i) Streaming service is for video, audio and flash content.
- (ii) The streaming service speed per session shall not exceed 500Kbps.
- (iii) Content to be streaming serviced shall be transcoded to be viewable for computers, smart phones and tablets.
- (iv) Only authenticated users shall be able to Access streaming on the Digital Repository, while all users shall be able to access video and audio streaming of the general spaces of the E-Portal (related with general information or events).

(f) Advanced Search Function

- (i) Search functions shall utilize natural language search of Spanish, key word search, basic and advanced search, Boolean search, search within searched items, complete match search, close match search, boundary search, etc.
- (ii) Searched items shall be viewed by ranking and by array/filtering categories.
- (iii) Search functions shall include key word completion, spelling check & correction functions.
- (iv) Search shall be performed on Colombia Aprende.
- (v) Statistics of search shall be stored and presented.

(g) Content Service

- (i) Content for students shall be categorized by such categories as 1. Author, 2. Public Objective (students, teachers, parents, etc) 3.

- Grade or groups of grades, 4. Competences, 5. Subject, 6. Format (type of content), 7. Language, 8. Date and etc.
 - (ii) Content for teachers shall be categorized by such categories as 1. Author, 2. Public Objective (students, teachers, parents, etc) 3. Grade or groups of grades, 4. Competences, 5. Subject, 6. Format (type of content), 7. Language, 8. Date and etc.
 - (iii) Content to be developed during the Project shall be serviced.
 - (iv) Content shall be personalized to each user by interest, user group and peer groups' interest, etc.
 - (v) Content shall be categorized and searched by media categories such as text, image, sound, video, document, etc.
- (h) e-Book Service
- (i) e-Book shall be provided to students and teachers.
 - (ii) Only e-Book that does not infringe any intellectual property rights shall be serviced.
 - (iii) e-Book shall be converted from any text based document to pdf and/or epub format document.
- (i) Community Service based on SNS
- (i) Community service based on SNS (Social Network Service) shall be serviced to students and teachers.
 - (ii) The Bidder shall propose which SNS will be utilized and propose a plan.
- (j) Web 2.0 Services (Forums, Blogs, Wikis, Chatting)
- (i) The Bidder shall propose what Web 2.0 services will be utilized and propose a plan.
- (k) Virtual Teacher Training
- (i) The bidder shall provide a LMS for Virtual Teacher Training (since month 3). This LMS shall be installed and delivered as a provisional solution until the new LMS within the new e-portal is operating. All the information gathered from the Virtual Teacher Training shall be migrated to the LMS on the e-portal.
 - (ii) LMS shall provide functions to register virtual teacher training content and to notify through e-Portal.
 - (iii) LMS shall provide functions for teachers to register for RIC teacher training courses including Master Teacher training, Leader Teacher training and other trainings authorized by the Purchaser.
 - (iv) LMS shall be able to accommodate 30 hours of pre-virtual courses

and 20 hours of post-virtual courses with 6,000 users one time.

- (v) LMS shall accommodate all the curricular analysis data and teaching objectives. It shall be inter-connected with the analysis data.
 - (vi) Services as chats, forums, online activities, quizzes and exams shall be provided.
 - (vii) Feedback functions shall be utilized for evaluation of trainee's reports.
 - (viii) Statistics shall be provided.
 - (ix) LMS shall be integrated with e-Portal functions such as forum, chat, etc.
 - (x) LMS shall support content streaming service. Users should be able to access and view content without downloading it.
- (l) Guidelines
- (i) Guidelines shall be provided for the services provided to teachers and parents.
 - (ii) Guidelines for teachers shall be serviced through HTML document or multimedia format. They may include content development manual for teachers, online teacher training manual, etc.
 - (iii) Guidelines for parents shall be serviced through e-book or multimedia format.
- (m) General Information Services (Notifications, Agenda, Events)
- (i) e-Portal shall be accessible by general public and users who do not log in to some information such as notifications, agenda, events, or any information the Purchaser wishes to publicly be open. Such information shall be managed by CMS.
- (n) Monitoring activity of authenticated users
- (i) Administration mode/menu shall be provided to manage authorized users.
 - (ii) Functions to distinguish active user, inactive users, withdrawn users by the rules set by administrators shall be provided. Administrators shall also have an authority to temporarily disable any service for and opened by inactive users.
 - (iii) Functions to restrict users who violate any third party rights, threat, humiliate, libel any other users or distribute or pose any immoral and/or sexually explicit media including text, picture, illustration, video, audio and others shall be provided to

administrators.

(o) e-portal General Statistics

- (i) General statistics related to the operation of e-Portal shall be provided to administrators.
- (ii) General statistics include daily/weekly/monthly/yearly statistics on page views, number of visitors, number of initial/second/repetitive visitors, number of authenticated users, and number of registered users.
- (iii) General statistics shall utilize multi-dimensional segmentation to categorize user groups and analyze by user groups.
- (iv) Functions to track page movement by users, analyze page input-output, average usage time shall be provided.
- (v) Major statistics shall be provided in graphs by period of time.

(p) Web Accessibility

- (i) e-Portal shall be accessible by the visually impaired.
- (ii) The visually impaired shall be able to access the information of e-Portal through keyboard and/or TTS program.

(q) Mobile Web Page Support

- (i) e-Portal shall support mobile web environment to provide adequate service to mobile devices with different screen ratio and resolutions.
- (ii) Mobile service may not include content that is not appropriate for mobile service. The Supplier shall recommend what service can be realized in mobile web environment to the Purchaser.

(r) Data Backup

- (i) Back-up system shall be customized for periodic data back-up from designated server or DBMS.
- (ii) The system shall provide functions to designate and change targets for back-up and depending on back-up policy, periodic back-up shall be performed.
- (iii) They system shall support back-up not only for the data inside the file system but also for the data managed through LDAP or DBMS.
- (iv) The system shall support full back-up, incremental back-up, differential back-up, etc.

(s) Legacy Data Migration

- (i) Legacy data from the current Colombia Aprende shall be migrated

to the new e-Portal. Selection of the legacy data to be migrated to the new e-Portal shall be proposed by the Supplier and decided by the Purchaser.

- (ii) The Supplier may select local agency to migrate the data. However, the Supplier shall bear all the responsibilities of the migration.

(t) Translation service for e-Portal

- (i) The proposed e-Portal shall provide the multi-language translation service for its content.
- (ii) The Bidder shall provide a solution for this service

3.9 Role & Responsibilities of the Stakeholders

(a) General Requirement

- (i) The Supplier shall propose a role & responsibilities model on the basis of the requirements stated below.
- (ii) The Bidder may propose a plan that best serves the Purchaser's objectives of the Component. The Bidder shall present the point of change management clearly.

(b) Benchmarking & Analysis & Design

Stakeholders	Role & Responsibility
MOE	<ul style="list-style-type: none"> • Review and approve all the reports • Select 5 e-portal sites for benchmarking (Including the Study of Users with 5 or 6 focus groups) • Review new e-portal design
Supplier	<ul style="list-style-type: none"> • Benchmark 5 e-portal sites. • Draft the "E-portal benchmarking Complete Report" • Analyze and design for new e-portal

(c) Implementation

Stakeholders	Role & Responsibility
--------------	-----------------------

MOE	<ul style="list-style-type: none"> • Review and approve all the reports • Provide a list of qualified human resources of minimum the number of Colombian experts required. In case MOE does not deliver the minimum number of potential experts on the list, the supplier will have the freedom to propose its own eligible experts according to MOE guidelines, until completing the number of people required. • Dispatch MOE staff to NIC and monitor the test progress
NIC	<ul style="list-style-type: none"> • Prepare all hardware and network infrastructure • Provide an engineer in acceptance test to help in its smooth progress
Supplier	<ul style="list-style-type: none"> • Purchase all software solutions for implementation • Establish the test-bed and development environment • Implement all services of e-portal • Submit the “Interim Report about Implementation ” • Deploy the developed programs and solutions to the servers • Prepare and submit the “Acceptance Test Plan” including test method, schedule, budget and target to MOE before the acceptance test begins • Provide operations costs for the Acceptance Test for auditors/inspectors to visit selected Lab Schools for Test • Submit the “Acceptance Test Complete Report” • Modify e-portal site according to feedback information • Submit the “Modification Complete Report” • Implement the web log analysis system • Submit the “Web log analysis system implementation Complete Report” • Provide the planning and migration cost for Colombian members • Submit the “Evaluation Plan” including evaluation method, schedule and target

(d) Training

Stakeholders	Role & Responsibility
MOE	<ul style="list-style-type: none"> • Review and approve all the reports
NIC	<ul style="list-style-type: none"> • Finalize the target users for operational training before operational training begins
Supplier	<ul style="list-style-type: none"> • Submit “Operational Training Plan”, which includes the target, method and period for the operational

	training <ul style="list-style-type: none"> • Submit the “Operational Training Complete Report” • Submit the “Awareness Plan” • Submit the “Awareness Program Complete Report”
--	---

3.10 Human Resource Requirement

(a) General Requirement

- (i) The Supplier shall propose a plan for human resources on the basis of the basic human resource requirements stated below and shall provide the certificates of experience. The bidder must deliver evidence that all the proposed personnel has given its consent to participate in the “ICT Education Capability Building in Colombia” Project. The Purchaser will reserve the right to verify the evidence. In case the consent was not given, the proposal shall be rejected.
- (ii) The Bidder may propose a plan that best serves the Purchaser’s objectives of the Component. However, the Bidder shall prove each human resource’s capabilities in the specific field. For e-Portal, the Bidder shall provide for human resources evidence that those have prior experience in open source architecture development, deployment or training.
- (iii) The Bidder may propose a greater number of people to perform the work, but never less than those indicated below..

(b) e-Portal development

Stakeholder	Human Resources	Duration	Requirement
Supplier (Colombian experts)	<ul style="list-style-type: none"> • 1 Information Architect • 1 Usability research • 1 User Interface Analyst 	12 months	<ul style="list-style-type: none"> • 3 years experience • Specific experience in conceptualization and building of web portals, information architecture, usability and user centered design.
Supplier (Korean experts)	<ul style="list-style-type: none"> • 1 Special Engineer (PM) • 1 Advanced Engineer (Architecture) • 2 Professional Programmers 	9 months	<ul style="list-style-type: none"> • 12 years experience • 9 years experience • 6 years experience

	<ul style="list-style-type: none"> • 3 Web Programmers • 1 Web Designer 		<ul style="list-style-type: none"> • 3 years experience • 3 years experience
--	---	--	--

* It is desired that all the engineers, programmers and planners are to have prior experience in open source architecture e-Portal development.

(c) e-Portal deployment and legacy data migration

Stakeholders	Human Resources	Duration	Requirement
Supplier (Colombian experts)	<ul style="list-style-type: none"> • 1 Professional Programmer 	12 months	<ul style="list-style-type: none"> • 6 years experience
	<ul style="list-style-type: none"> • 3 Programmers 		<ul style="list-style-type: none"> • 3 years experience
	<ul style="list-style-type: none"> • 1 Web Designer 		<ul style="list-style-type: none"> • 3 years experience
	<ul style="list-style-type: none"> • 2 Operation Engineers 		<ul style="list-style-type: none"> • 3 years experience
Supplier (Korean experts)	<ul style="list-style-type: none"> • 1 Advanced Engineer (Architecture) 	1.5 months	<ul style="list-style-type: none"> • 9 years experience
	<ul style="list-style-type: none"> • 1 Professional Programmer 		<ul style="list-style-type: none"> • 6 years experience
	<ul style="list-style-type: none"> • 2 Web Programmers 		<ul style="list-style-type: none"> • 3 years experience

* It is desired that all the engineers and programmers are to have prior experience in open source architecture e-Portal development.

(d) Evaluation

Stakeholders	Human Resources	Duration	Requirement
MOE (Colombian experts)	<ul style="list-style-type: none"> • 6 Evaluators 	1.5 months	<ul style="list-style-type: none"> • 3 from MOE • 3 from NIC
Supplier (Korean experts)	<ul style="list-style-type: none"> • 1 Special Engineer (Project Manager) 	1.5 months	<ul style="list-style-type: none"> • 12 years experience • Computer science background

* No salary is required for the Colombian experts. However, the Supplier shall be responsible for the appropriate evaluation setting.

(e) Training

Stakeholders	Human Resources	Duration	Requirement
MOE (Colombian experts)	<ul style="list-style-type: none"> • 1 Manager 	1.5 month	<ul style="list-style-type: none"> • 6 years experience
	<ul style="list-style-type: none"> • 5 Web masters 		<ul style="list-style-type: none"> • 3 years

	<ul style="list-style-type: none"> • 2 Web designers 		<ul style="list-style-type: none"> • 3 years experience
	<ul style="list-style-type: none"> • 1 Database administrator 		<ul style="list-style-type: none"> • 3 years experience
	<ul style="list-style-type: none"> • 1 Server engineer 		<ul style="list-style-type: none"> • 3 years experience
	<ul style="list-style-type: none"> • 1 Network engineer 		<ul style="list-style-type: none"> • 3 years experience
Supplier (Korean experts)	<ul style="list-style-type: none"> • 1 Professional programmer • 1 Programmer 	1.5 month	<ul style="list-style-type: none"> • 6 years experience • 3 years experience

* It is desired that all the trainers are to have prior experience in open source architecture e-Portal development and training.

* No salary is required for the Colombian experts. However, the Supplier shall be responsible for the appropriate training setting.

4 Content Development and Management

4.1 Objective of the Component

The Content development component¹ has the following objectives;

- (a) To provide national guidelines to develop and manage high-quality digital content (digital resource, learning object, unit of learning and courseware)
- (b) To provide quality control guidelines to manage the quality of the content
- (c) To provide content development and management manuals for professionals and teachers
- (d) To provide national guidelines for Content Development and Management Standardization (metadata, formats, copyrights, and development standards).
- (e) To analyze current educational public policy and Basic Standards of Competence for the selected 3 subject (Language (Spanish), Mathematics, Natural Science) and information related to social, cultural, and economic context, available through the Information Systems of MOE and manage and share the outcomes among various educational stakeholders as a reference
- (f) To provide a Content Development and Management Supporting System
- (g) To develop 33 courseware for the selected 3 subjects and make them available to e-Portal.
- (h) To enhance content development and management capabilities of the selected 5 RIC
- (i) To qualify staff of the Content Development Research office (CDR) to acquire adequate knowledge of content development and management process and to transfer the knowledge to the participating organizations
- (j) To boost content development industry by creating a business model in content development

¹Content development refers to the processes of analysis, design, development, implementation, and evaluation of digital content. Content management refers to the processes of organizing, cataloging, hosting, storage, and publishing of digital content.

4.2 Conceptual design of the Component

To accomplish the objectives of the Project, this component is designed to develop 33 courses (courseware) for all the subjects and grades listed in 4.4 by involving all 5 RIC to be established through the Project.

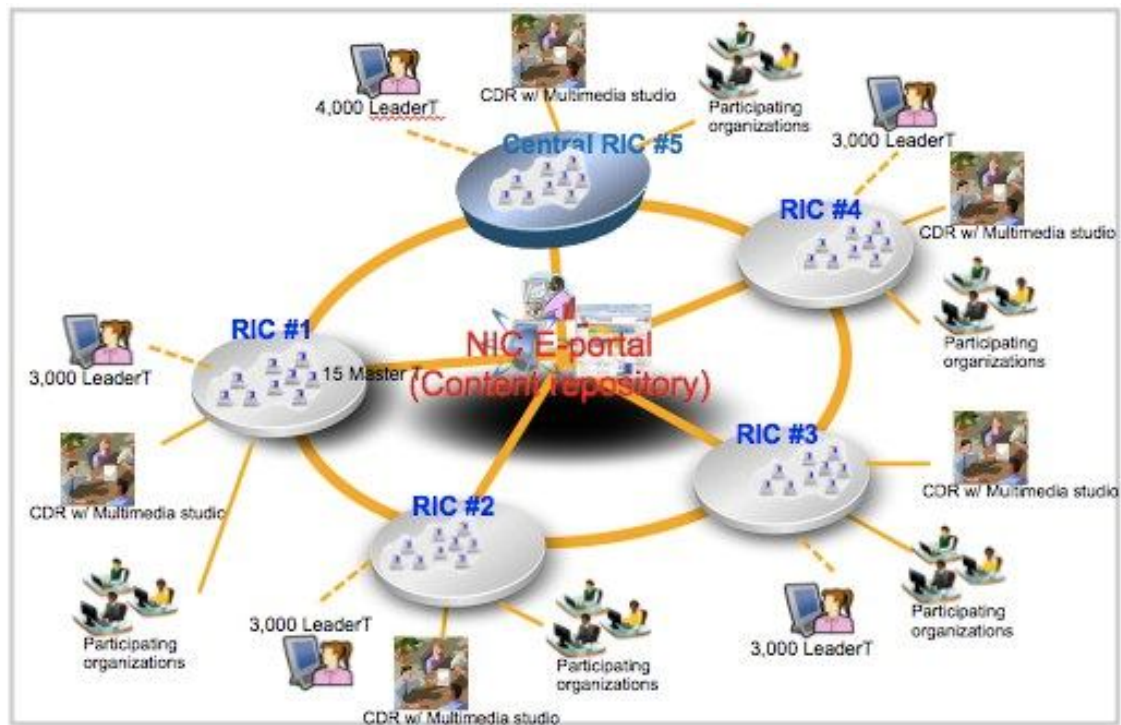

4.3 Definitions

(a) Courseware

It's a learning environment mediated by ICT, provided with the conditions to develop teaching and learning processes, to achieve the Teaching Objectives established to comply the Basic Standards of Competence²(MOE, 2012).

For this project, a courseware is constituted by a collection of 5 **Units of Learning** that answer to the fulfillment of **Basic Standards of Competence** of a **Group of Grades**. The **Group of Grades** are:

- 1-3
- 4-5
- 6-7
- 8-9

² <http://www.mineducacion.gov.co/cvn/1665/article-116042.html>

- 10-11

For each **Grade Group** we have a **Courseware of Intermediate Level of Complexity** and a **Courseware of Advanced Level of Complexity**, except for Grade Group 1-3, which has an additional **Basic Level of Complexity**. The levels of complexity are established from an educational analysis of the **Basic Standards of Competence**.

As an example, for Grade Group 10-11, on Natural Sciences, the 5 Units of Learning would be divided the next way:

- 2 Units of Learning on Physical Processes
- 2 Units of Learning on Chemical Processes
- 1 Unit of Learning on Bio-Technological Processes

On a **Courseware**, there must be described, among others, the next features:

- Group of Grades
- Subject
- Competence
- Level of Complexity

(b) Unit of Learning (UoL)

It's a courseware component, provided with the conditions to develop teaching and learning processes, to achieve Competences on students.

For this project, a **Unit of Learning** is a collection of **Learning Objects** and each one can have around 6 to 8 **Learning Objects**, coherently articulated.

On a **Unit of Learning**, there must be described, among others, the next features:

- Learning Objectives related to competence
- Conceptual content
- Procedural content
- Attitudinal content
- Learning activities
- Assessment activities

(c) Learning Object (LO)

It's a digital entity with information and knowledge, and the purpose of complying with **Learning Objectives**.

For this project, a **Learning Object** is composed of one or several **Digital Resources** coherently articulated, that complies with **Learning Objectives**.

A **Learning Object** can have around 33 to 35 **Digital Resources**, and it is on the **Learning Object** where these features are described on a concrete way:

- Learning Objectives
- Conceptual content
- Procedural content
- Attitudinal content
- Learning activities
- Assessment activities

(d) Digital Resources

It's an entity of digital information. It can be of diverse types such as audiovisual, sonorous, textual, visual, multimedia, etc.

For this project, Digital Resources must be coherently articulated with the purpose of complying **Learning Objectives** defined on the **Learning Object**.

The relationship between all types of content is shown below:

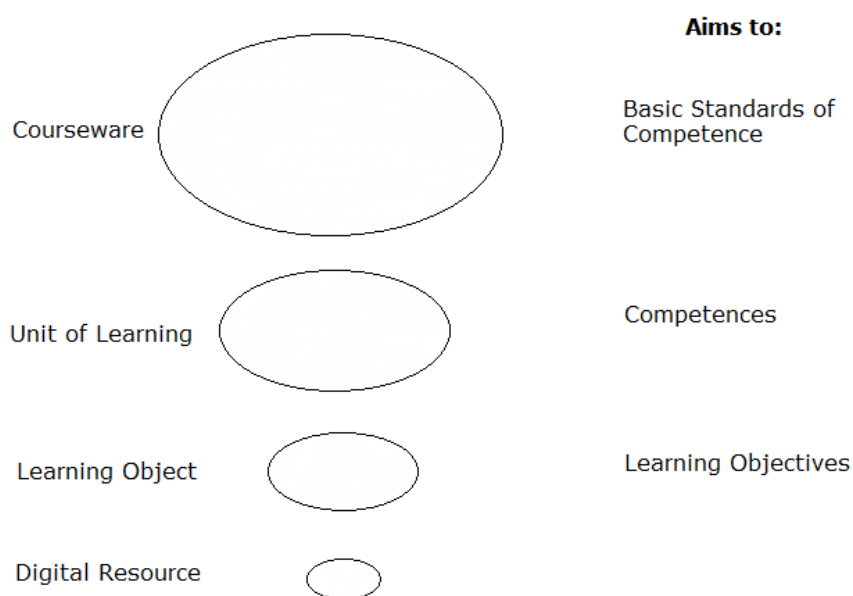

4.4 Target subjects and grades

Subjects	Mathematics, Natural Science, Language (Spanish)
Grades	Grade 1 ~ Grade 11 (All 11 grades of elementary, middle and high school in Colombia)

4.5 Deliverables

Sub-Component	Deliverables	Number
Content Development and Management Manual	<ul style="list-style-type: none"> • Content Development and Management Manual for Professionals • Content Development and Management Manual for Teachers • Content Quality Evaluation Manual for the Quality Control Teams • Process Management Manual for RIC coordinators 	<p style="text-align: center;">1</p> <p style="text-align: center;">1</p> <p style="text-align: center;">1</p> <p style="text-align: center;">1</p>
Content development and management Standardization	<ul style="list-style-type: none"> • Content Development and management standardization Guidelines • Metadata application profile • Metadata and data uploading and downloading functionality 	<p style="text-align: center;">1</p> <p style="text-align: center;">1</p> <p style="text-align: center;">1</p>
Content Development	<ul style="list-style-type: none"> • Content Development and Management Supporting System & database • Unit of learning per subject (Language, Mathematics, Natural Sciences) for pilot project (each RIC team is required to produce at least 1 UoL during pilot project (minimum 5 UoL in total)) • Courseware for the Component (1 courseware per each grade and 11 courseware per each subject) 	<p style="text-align: center;">1</p> <p style="text-align: center;">1-2 per subject</p> <p style="text-align: center;">33</p>

1 course (courseware) consists of 5 units of learning; each unit of learning contains 6-8 learning objects and each learning object contains 33~35 digital resources. The number depends on the outcome of the analysis of the current educational public policy for the selected 3 subjects (Language (Spanish), Mathematics, Natural Science) and information related to social, cultural and economic context, available through the Information Systems of MOE. The analysis data is to be prioritized.

33 courses (courseware) with approximately 32,600 digital resources are to be developed throughout the Project.

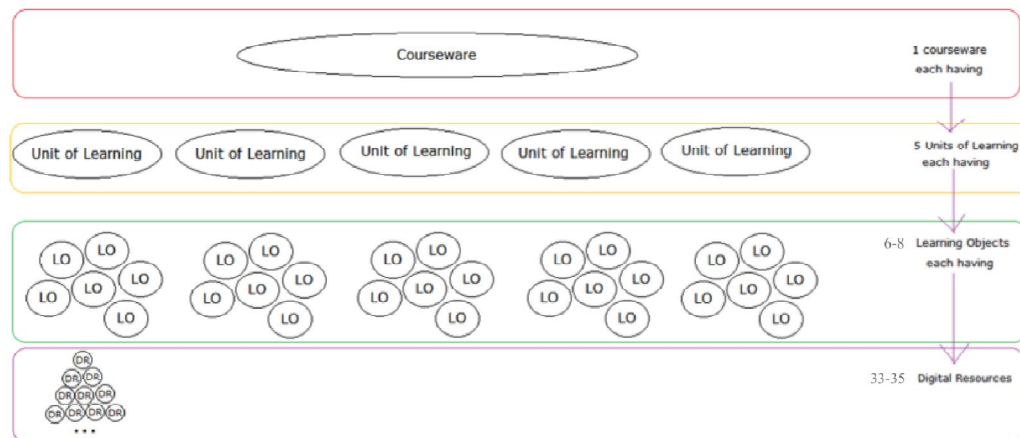

4.6 General Requirements

- (a) The Purchaser requires to analyze and to develop the Courseware with 5 RIC on the subjects and grades specified in 4.5.
- (b) The Purchaser also requires to develop manuals for content development and management with standardized processes and national educational metadata guidelines that meet international standards and that serves all national and international stakeholders.
- (c) The Bidder shall propose a plan to develop the Deliverables specified above that best serves the Purchaser's objectives. The methodology to be adopted for the Component shall be clearly stated in a proposed plan.
- (d) The Bidder shall transfer all exclusive rights, including all transferable intellectual property rights (IPR) and use rights, in the deliverables, including their specification, algorithms and architectural approach. The Bidder shall deliver the technical solution and specifically all rights of developed software, sources and comments as contained therein. Such rights shall include the absolute right to develop, or modify the developed software.
- (e) The Bidder shall acknowledge that 5 RIC to be established during the Project are to be involved in the content development process. The Bidder shall propose a detailed plan to work 5 RIC including role and responsibilities of participating members (Refer to 4.9).
- (f) Courseware shall not generate/create/incur any kind of costs, once they are handed over to the Purchaser and there shall be no license fees for the Purchaser, once the Courseware is handed over to the Purchaser.
- (g) There shall be no limits on the number of users that can use the Courseware.
- (h) The Supplier shall train 15 RIC members during the pilot project (which is going to take place on one of the multimedia classrooms from Central

RIC) and 12-30 RIC members for each RIC (Total of 60 – 150) during the main content development process to maintain and modify the courseware, after the first Courseware is handed over to the Purchaser.

- (i) The Bidder shall provide at least 2 sample content (one Unit of Learning and one learning object) to demonstrate its experience and capabilities of content development and management.
- (j) The Bidder shall propose the proportions of the content development between the Supplier and the Purchaser (5 RIC) and propose the development cost for 5 RIC overall. In addition, the Bidder shall propose a plan to support the operational cost of Colombian experts specified in 4.9 Role and Responsibilities.
- (k) The source code for the courseware and all its components shall be supplied by the Bidder, except any commercial software/system to be used on the development of content.

4.7 Technical Requirements

(a) Content Development and Management Manual

The Bidder shall propose a plan to develop 4 sets of the manuals on the basis of the following information;

- (i) The content development and management manual for professionals is to train staff of CDR of RIC to develop high quality, complex digital resources and courseware from analysis to implementation.
- (ii) The content development and management manual for teachers is to assist teachers to develop different types of content.
- (iii) The content quality evaluation manual for the Quality Control Teams is to guide the Teams to evaluate content developed both by professionals of RIC and by teachers.
- (iv) The process management manual is for coordinators of RIC to manage the overall process of content development. It is similar to the content development manual for professionals but focus on the management and evaluation sides of the process.

(b) Content Development and Management Standardization Guidelines

The Bidder shall propose a plan to develop 2 sets of the manuals along with the template on the basis of the following information;

- (i) The content development and management standardization guidelines are to standardize everything related to content development and management.
- (ii) The metadata application profile is to include standardization of the metadata on the basis of LOM, combined with other international

standards; additionally, it shall document information on how to use it and fill in the metadata.

- (iii) A Content Development and Management Supporting System functionality to upload and download a large quantity of data and metadata.

(c) Content Development

- (i) The Courseware shall have a professional outlook and shall conform to the Visual Identity rules to be developed.
- (ii) The Courseware shall meet general requirements stated for training integrated systems in ISO, IEC, IEEE, IMS and other standards in this field.
- (iii) The Courseware shall be developed in compliance with the Sharable Content Object Reference Model, SCORM (version to be applied will be consulted and decided later, before the content development manuals drafting starts) and shall be functional and viewable in any internet browsers of any devices.
- (iv) Regular computer users with limited permissions (i.e. not necessarily administrators) shall be able to run and/or download the courseware.
- (v) The need to install any software not contained on the distribution media shall be avoided.
- (vi) The possibility to run and use the Courseware under iOS and Android is desirable.
- (vii) The Courseware shall use mixed-media formats, i.e. text, audio, video, animation, as well as interactive games and tests, appropriately combined to the learning aspects being delivered effectively.
- (viii) The Courseware shall provide function to restart at the same location, if training was halted or not fully completed. It shall be apparent to the user which sub-modules or lessons he or she has already visited and which modules he or she has successfully completed.
- (ix) The Courseware shall include tutoring options where appropriate.
- (x) Determining a learner's progress and understanding shall be implemented following tests that are engaging and varied, containing at least some of the following functions (but not limited to these):
 - (aa) Click to answer tasks: clicking on elements in graphics and passive animations
 - (bb) Random selection of questions from pool of questions

- (cc) Limited time (time function and display) and limited number of attempts (with display) with a scoring system
- (dd) Single choice (with text, graphics and passive animations)
- (ee) Sorting or putting things in the right order (e.g. steps in the process)
- (ff) Drag and Drop Tasks, i.e. moving elements with the mouse to a designated place
- (gg) Functions such as presentation of information
- (hh) Feedback informing the learner whether the solution of a task was correct or incorrect
 - (ii) Detailed feedback to the learner after completion of a task. Recommending documents for required reading or self-study for particular subjects or training objectives
 - (jj) Hints to the learner about possible ways to solve a task
- (kk) The Courseware shall provide start, stop, pause functions and cue points to control animations and videos.
- (ll) The Courseware shall provide full text search capabilities through all the modules as well as metadata based search (for graphics, audio, video, etc.).
- (mm) The Supplier shall create and record Audio portions as appropriate.
- (nn) Any audio portions in the digital materials, added by the Supplier, shall be recorded by a native or a fluent speaker of the language being recorded.

(d) Content Development and Management Supporting System

- (i) The Purchaser seeks to obtain a solution that will aid instructional staff to design, develop, deploy and maintain an integrated, sustainable skill/competency based curriculum, according to educational policies of the Republic of Colombia.

The system shall support everything that any educational stakeholder needs to establish and maintain the content development and management environment in an information system form, including but not limited to:

- (aa) Facilitate the analysis of current public education policies of the Republic of Colombia, and analysis of other available resources, to identify skill/competencies defined for all grades of elementary, middle and high school.
- (bb) The formulation of objectives associated with the skill/competencies such that all skill/competencies are

- directly addressed and electronically connected to measurable teaching/learning objectives.
- (cc) A functionality that allows the development of assessment items (test questions) as needed to measure objective mastery against its competency standard. Each assessment item shall be electronically connected to the appropriate, corresponding objective and the corresponding competencies.
 - (dd) Arrangement of the teaching objectives in a learning hierarchy order such that their prerequisite relationships are established and maintained.
 - (ee) Development of learning content for each objective sufficient to enable (teach) student mastery of the objective, as demonstrated by successful completion of the associated assessment items.
 - (ff) Arrangement of the objectives (with assessment items) into a curriculum to produce a completely integrated instructional curriculum comprised of courseware, units of learning, learning objects and digital resources that are demonstrably tied back to the core competencies.
 - (gg) The ability to automate the generation of assessment instruments (tests/quizzes, exams) for courseware, units of learning, learning objects and digital resources, even on-demand by members of the teaching staff.
 - (hh) Sharing of common instructional materials across instructional programs or grade levels to re-use, rearrange and continually update the curricula while avoiding redundant effort in curriculum development and ongoing maintenance.
 - (ii) Searching, by tracing the connection from competencies to curriculum, and by other means (key-word search, etc.), in order to find and resolve areas of the curricula that are impacted by change thereby maintaining curriculum design integrity and fostering continually updating of curriculum quality.
- (ii) The system is to be used by subject-matter experts, instructional designers, and teachers participating on the teacher training process. Result of its use will be a visibly integrated and sustainable teaching/learning system foundation based on measurable competency standards.
 - (iii) It is desirable for the Bidder to supply with the system a database of pre-existing core competencies for K – 12 from other countries

with conditions similar to that of the Republic of Colombia.

- (iv) The instructional content is to be developed for the teaching objectives as “re-usable educational resources (courseware, units of learning, learning objects and digital resources)”.
- (v) Once developed, these independently-stored educational resources are to be sequenced into printed lessons, supplementary teaching aids, classroom sessions, CBT modules, or web-based learning, and are reused as often as they are needed.
- (vi) The Purchaser also seeks to obtain a software program or related capability that will enable a Learning Management System (LMS), any LMS abiding by SCORM standards, to be able to access the database created by the Content Development and Management Supporting System described above. This program, or application interface, would serve as “middleware” by making data developed and stored in a database through use of the Content Development and Management Supporting System available to the LMS. In case the Content Development and Management Supporting System has integrated functions described below, no such program is required. The program or interface shall support everything all educational stakeholders need to directly utilize the data produced in the database in an on-line setting including, but not limited to:
 - (aa) Generate tests (random test generator) for on-line deployment to the students on demand from a computer station, ready for student response.
 - (bb) Provide an interface that is easy for students at all grade levels to use to answer the questions, review or change answers before submitting the exam, and finally submit the exam.
 - (cc) Upon submitting the test, the system will electronically grade the test, notify the student of the results (pass, no pass, grade, etc.) as well as notify via e-mail the designated teacher/instructors of the results.
 - (dd) Provide the capability to offer on-the-spot review and remediation to the student, based on test results. Remediation will be based on the presence of lesson content directly associated with the test question, and the ability of the desired program or interface to display the content per missed test question.
 - (ee) Provide an automatic update to the LMS such that the LMS remains the system of record for all student test results.
 - (ff) Similar to the process for generating exams, cause the system to generate actual Course/lesson materials for

display through the LMS based on the content produced and stored in the database.

- (gg) Enable students to progress through a courseware, including the use of bookmark and other features standard for a LMS. Provide a variety of options such as “test required”, read the lesson only” no test, etc.
- (vii) The program will work with “single sign-on”; a student can log into (sign on) the LMS, and upon requesting an exam or lesson, the LMS can open display the desired exam or lesson based on the database but without requiring the student to log onto another (middleware) program.
- (viii) In addition to sending courseware progress and exam results back to the LMS, the program will send test results and general reports back to the database such that the Content Development and Management Supporting System can perform its own analysis and tracking functions. For example, the test results will be stored for test question analysis in order to identify problems with questions and promote continual updating of the test questions in the database.
- (ix) Required hardware and additional software to run the Content Development and Management Support system shall be proposed. The Content Development and Management Supporting System shall be integrated on the architecture as shown below:

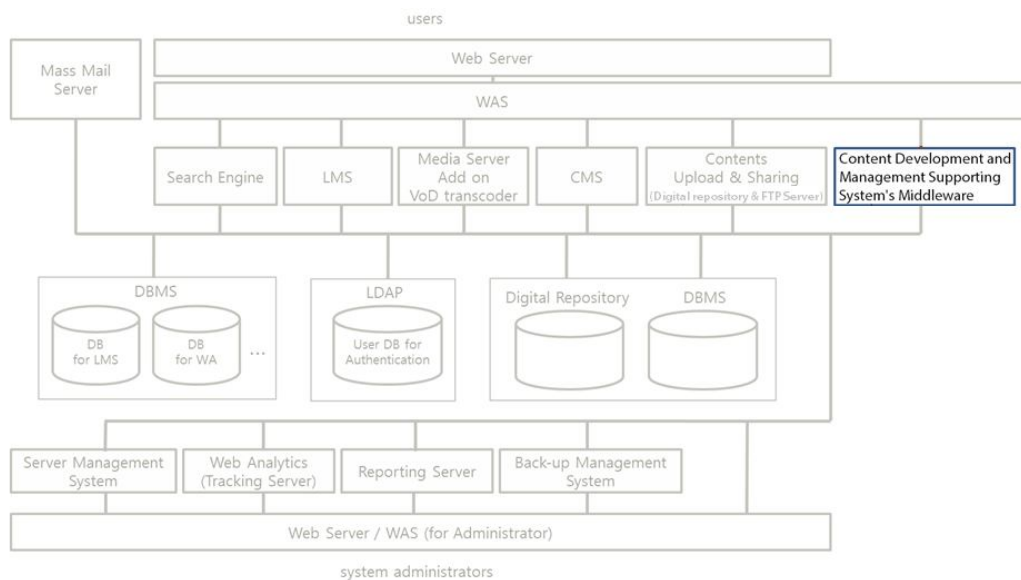

- (x) Cloud service is not acceptable and there shall not be any duplication (or redundancy) of repositories. The repositories proposed for e-Portal shall contain digital content produced through this component. Duplication or redundancy of repositories will

result in ‘non-responsive’ or ‘not proposed’ of the proposed system.

4.8 Functional Requirements

(a) Content Development and Management Manual

- (i) 4 Korean experts and 6 Colombian experts for 3 months are to jointly develop 4 sets of the manuals described in 4.5.
- (ii) Each set of manual shall focus on its target audience. The content development and management manual for teachers is to be written in simple language for non-IT savvy teachers to follow step by step.

(b) Content Development and Management Standardization Guidelines

- (i) 1 Korean expert for 3 months is to develop the content standardization manual described in 4.5.
- (ii) The content development and management standardization guidelines are to be used for all educational content developed not only through this Project but also through others projects.

(c) Content Development

- (i) The Courseware shall be pedagogically aimed at the target audience (teachers and students from grade 1 to 11) and support and motivate them in the learning process; the manner in which the content is presented shall attract them and to entice them to read more and to want to continue with the other modules.
- (ii) Learning objectives shall be achieved through learning information content followed by testing of the training objectives, to ensure understanding.
- (iii) The courseware shall be gender, religion, and politically neutral.
- (iv) The digital resources in the Courseware shall be organized or generated as a learning object and a unit of learning.
- (v) Each Courseware shall be designed to be delivered in, at least, the following ways:
 - (aa) As a cross-platform Web-Based Training (WBT) module that can be hosted on a SCORM certified Learning Management System (LMS)
 - (bb) As a stand-alone, self-contained Computer-Based Training (CBT) module distributed on DVD and running on a local computer under Windows XP/ or Vista or Windows 7 (or

later) or Mac OS X 10.7 (or later) operational system

- (vi) The Supplier shall provide and maintain an online content development process management system and shall provide access for the Purchaser to this tool. Every stakeholder shall be able to access to this system and check the status of the component progress.
 - (vii) The Supplier shall maintain an online version management tool or tracking system and shall provide access for the Purchaser to this tool. The Purchaser shall be able to directly file issues in this tool. Issues filed by Supplier shall be visible to the Purchaser. The version management tool shall provide information about what features have been resolved in what software version.
 - (viii) The Supplier shall maintain a quality assurance log for all deliverables and shall share this log with the Purchaser. The Supplier shall also report on the performance criteria as agreed in the implementation plan
- (d) Content Development and Management Supporting System
- (i) The system shall be provided immediately after the commencement of the Project. The Bidder is advised to propose the pre-packaged system that meets all the requirements stated above or develop one prior to the commencement of the Project.
 - (ii) In case the Bidder is to develop or customize a system, the Bidder shall demonstrate the system on the proposal and, shall provide a plan to develop one prior to the commencement of the Project with the detailed timeline.
 - (iii) The proposed system shall be integrated with e-Portal. The cost related to the integration and customization shall be borne by the Supplier. The Bidder shall propose a detailed plan to integrate the proposed system with the proposed e-Portal.
 - (iv) The Bidder shall propose a detailed plan of how the proposed system will support the process of curricular analysis. Without clear justification of these functions, the proposed system will be considered 'non-responsive' or 'not proposed'. Just publishing the analyzed curricular data on the system is not acceptable.
 - (v) The Bidder shall propose a plan to secure (and restrict access to) the crucial data such as curricular analysis data.
 - (vi) Unlimited access to the proposed system data (database to be decided by the Ministry to be provided to the public) shall be guaranteed. General data shall be available without restriction of the number of users (Crucial data may be available for only authorized personnel (In this case, the Bidder shall specify which data is crucial and which is general)

- (vii) The Bidder is advised to provide a curricular database of other countries (one or more) on the system it is proposing as a reference to develop Colombian curricular database. Such data shall be either in English or Spanish. Colombian Basic Standards of Competences shall also be considered.
- (viii) The Bidder is advised to provide a web site URL that the Purchaser can try the system or at least view system demo or presentation video clips.

4.9 Role & Responsibilities of the Stakeholders

(a) General Requirement

- (i) The Supplier shall propose a role & responsibilities model on the basis of the requirements stated below.
- (ii) The Bidder may propose a plan that best serves the Purchaser's objectives of the Component. The Bidder shall present the point of change management clearly.

(b) Content Development and Management Manual

Stakeholders	Role & Responsibility
MOE	<ul style="list-style-type: none"> • Approve the definition and the structure of the manuals • Review the quality of the manuals • Oversee and assist the selection process of Colombian experts by the Supplier • Provide a list of qualified human resources of minimum 6 potential experts for the Supplier to select 6 Colombian experts to assist Korean experts to draft content development and management manual. . In case MOE does not deliver the minimum number of potential experts on the list, the supplier will have the freedom to propose its own eligible experts according to MOE guidelines, until completing the number of people required.
Supplier	<ul style="list-style-type: none"> • Select, provide and maintain 4 Korean experts • Select, provide and maintain 6 Colombian experts to assist Korean experts to draft content development and management manual • Provide space for 6 Colombian experts and 4 Korean experts for 3 months • Provide adequate office supplies for experts • Draft 4 sets of content development manuals (Refer to the Deliverables)

(c) Content development and management Standardization

Stakeholders	Role & Responsibility
MOE	<ul style="list-style-type: none"> • Approve the definition and the structure of the Content development and management standardization guidelines, metadata application profile and metadata & data uploading and downloading functionality • Review the quality of the Content development and management standardization guidelines, metadata application profile and metadata & data uploading and downloading functionality • Provide designated staff for interviews with Korean experts
Supplier	<ul style="list-style-type: none"> • Select, provide and maintain 1 Korean expert • Provide space for 1 Korean expert for 3 month • Draft the guidelines and the template specified in the Deliverables (Refer to the Deliverables)

(d) Content Development

Stakeholders	Role & Responsibility
MOE	<ul style="list-style-type: none"> • Review the quality of the content • Oversee and assist the selection process of Colombian experts by the Supplier and RIC • Provide a list of qualified human resources of minimum 18 potential experts for the Supplier to select 18 Colombian subject matter experts for the selected 3 subjects for curricular analysis. In case MOE does not deliver the minimum number of potential experts on the list, the supplier will have the freedom to propose its own eligible experts according to MOE guidelines, until completing the number of people required • Provide a list of qualified human resources of minimum 15 potential experts for the Supplier to select 15 Colombian Evaluators for the Quality Control Team. In case MOE does not deliver the minimum number of potential experts on the list, the supplier will have the freedom to propose its own eligible experts according to MOE guidelines, until completing the number of people required.

RIC(Central)	<ul style="list-style-type: none">•Select, provide and maintain minimum 12 content development specialists including 2 studio specialists (In case more specialists are required to deliver all the deliverables to the Supplier, RIC is responsible to do so with all the necessary measures including hiring more people, using the local currency portion of the budget)•Select and provide 3 pilot project participants out of the above mentioned content development specialists (1, pedagogical expert, 1 instructional designer and 1 content developer) to participate on the pilot project of content development, which is going to take place at the Central RIC•Develop and deliver 9 courseware for acceptance test by the Supplier and MOE (Acceptance test shall be the basis of the payment)•Evaluate the quality of the content provided by the participating organizations & generate quality control log•Evaluate the quality of the content provided by the teachers, amend the content in case those content is included as the deliverables& generate quality control log•Upload the evaluated content to the internal data server and to the e-Portal repository•Manage that teachers generate metadata for the content they develop•Update metadata for the content in Colombia Aprende (Approximately 5,000 content)•Maintain the CDR & multimedia studio facilities
--------------	--

RIC(Region)	<ul style="list-style-type: none"> •Select, provide and maintain minimum 12 content development specialists including 2 studio specialists (In case more specialists are required to deliver all the deliverables to the Supplier, RIC is responsible to do so with all the necessary measures including hiring more people, using the local currency portion of the budget) •Select and provide 3 pilot project participants out of the above mentioned content development specialists (1, pedagogical expert, 1 instructional designer and 1 content developer) to participate on the pilot project of content development, which is going to take place at the Central RIC •Develop and deliver 6 courseware for acceptance test by the Supplier and MOE (Acceptance test shall be the basis of the payment) •Evaluate the quality of the content provided by the participating organizations & generate quality control log •Evaluate the quality of the content provided by the teachers, amend the content in case those content is included as the deliverables & generate quality control log •Upload the evaluated content to the internal data server and to the e-Portal repository •Manage that teachers generate metadata for the content they develop •Update metadata for the content in Colombia Aprende (Approximately 5,000 content for each RIC) •Maintain the CDR & multimedia studio facilities
-------------	--

Supplier	<ul style="list-style-type: none"> • Provide the component management service • Select, provide and maintain 2 curricular experts for 4 months • Train Central RIC members (Select and provide 3 content trainers for 2 months) and coordinate with participants of the pilot project at the Central RIC • Select, provide and maintain 18 Colombian subject matter experts for the selected 3 subjects for curricular analysis • Train 4 other RIC members (Select and provide 6 content trainers for 3 months) • Provide operational costs for the pilot project participants • Provide operational costs for the content trainers to visit RIC, according to the training plan • Provide space for 18 Colombian experts and 2 Korean experts for 4 months • Provide space for 15 Colombian evaluators for 8 months • Select, provide and maintain 15 Colombian Evaluators for the Quality Control Team • Provide operational costs for the Colombian Evaluators of the Quality Control Team, to pay minimum 1 visit per month to RICs, according to Project Schedule (minimum 1 member of the Quality Control Team per RIC) in case these Evaluators are not stationed at RIC • Manage the Evaluators to evaluate the quality of the content provided by RIC & generate quality control log • Manage the Evaluators to evaluate the quality of the content provided by the teachers, amend the content in case those content is included as the deliverables& generate quality control log • Validate the quality of the content provided by all RIC • Provide adequate office supplies for experts • Provide a systematic analysis system and database to support curricular analysis • Analyze the curricula for the selected 3 subjects • Generate teaching objectives for the analyzed curricula • Manage the curricula database and share with RIC • Manage the pilot project development process • Manage the content development process • Provide development cost to RIC according to the proportions of the development divided between the Supplier and the 5 RIC
----------	---

4.10 Human Resource Requirement

(a) General Requirement

- (i) The Bidder shall propose a plan for human resources on the basis of the basic human resource requirements stated below and shall provide the certificates of experience. The bidder must deliver evidence that all the proposed personnel has given its consent to participate in the “ICT Education Capability Building in Colombia” Project. The Purchaser will reserve the right to verify the evidence. In case the consent was not given, the proposal shall be rejected..
- (ii) The Bidder may propose a plan that best serves the Purchaser’s objectives of the Component. However, the Bidder shall prove each human resource’s capabilities in the specific field.
- (iii) The Bidder may propose a greater number of people to perform the work, but never less than those indicated below”
- (iv) The Bidder shall propose a human resource allocation plan to be clear on which human resource will perform which role of the project.

(b) Content Development and management Manual

Stakeholder	Human Resources	Duration	Requirement
Supplier (Colombian experts)	<ul style="list-style-type: none"> • 3 Pedagogical experts • 3 Teachers 	3 months	<ul style="list-style-type: none"> • See below for requirements
Supplier (Korean experts)	<ul style="list-style-type: none"> • 2 Instructional designers • 2 content developers 	3 months	<ul style="list-style-type: none"> • See below for requirements

The requirements for Colombian experts are stated below:

- (i) 3 pedagogical experts: Bachelor or Master’s degree in areas related to education. Experience in didactic design or teaching/learning methodologies in the subjects of Mathematics, Natural Sciences and Language (1 person per subject). Experience in teaching the subjects of Mathematics, Natural Sciences and Language (1 person per subject). Participation in projects of ICT use in education is preferable.
- (ii) 3 teachers: Bachelor or Master’s degree in areas related to education. Experience in teaching the subjects of Mathematics, Natural Sciences and Language (1 person for each subject) in elementary, middle or high school. Participation in projects of ICT use in education is preferable.

It is recommended for 4 Korean experts to meet the following requirements;

- (i) Minimum 10 years of experience in content development for all 4 Koreans
 - (ii) For instructional designers, educational background in the subjects of education, educational technology, instructional design, computer education or computer science
 - (iii) No specific educational requirements for content developers and multimedia developers
 - (iv) English proficiency is highly recommended
- (c) Content development and management Standardization

Stakeholder	Human Resources	Duration	Requirement
Colombia	• None	None	• None
Supplier (Korean experts)	• 1 Metadata expert	3 months	• See below for requirements

It is recommended for 1 Korean expert to meet the following requirements;

- (i) Minimum 10 years of experience in content development
 - (ii) Educational background in the subjects of education, educational technology, instructional design, computer education or computer science
 - (iii) Doctorate degree on the areas related to Education is highly recommended
 - (iv) English proficiency is highly recommended
- (d) Curricular Analysis (Content development and management support)

Stakeholder	Human Resources	Duration	Requirement
Supplier (Colombian experts)	• 18 Curricular analysts	4 months	• See below for requirements
Supplier (Korean experts)	• 2 Curricular analysts	4 months	• See below for requirements

The requirements for Colombian experts are stated below:

- (i) 18 curricular analysts: Bachelor or Master's degree in areas related to education. Experience in teaching the subjects of Mathematics, Natural Sciences and Language, 6 people on each

subject, like shown next: 1 expert on 1-3 grade, 1 expert on 4-5 grade, 1 expert on 6-7 grade, 1 expert on 8-9 grade, 1 expert on 10-11 grade, 1 reviewer. Score of 80% in the promotion and relocation test is preferable. Experience in curricular planning or coordination in the subjects of Mathematics, Natural Sciences and Language is preferable. Experience in ICT training is preferable.

It is recommended for 2 Korean experts to meet the following requirements;

- (i) Minimum 5 years of experience in content development for all 2 Koreans
 - (ii) Minimum of 2 years of experience using or providing the proposed Content Development and Management Supporting System
 - (iii) No specific educational background is required but education-related educational background is preferred and master's degree or doctorate degree on the areas related to Education is preferable
 - (iv) English proficiency is highly recommended
- (e) Content Development

Stakeholder	Human Resources	Duration	Requirement
Colombia - RIC (Colombian experts)	<ul style="list-style-type: none"> • 60 Content developers from RIC 	10-12 months	<ul style="list-style-type: none"> • 10 Pedagogical experts • 10 Instructional designers • 10 Content developers • 10 Multimedia developers • 10 Programmers • 10 Studio experts • See below for requirements
	<ul style="list-style-type: none"> • 75 supporting Content developers from RIC 	4-8 months	<ul style="list-style-type: none"> • 5 Pedagogical experts • 5 Instructional designers • 60 Content developers • 5 Programmers • See below for mobilization

			schedule
Supplier (Colombian experts)	<ul style="list-style-type: none"> • 15 Evaluators 	8 months	<ul style="list-style-type: none"> • See below for requirements
Supplier (Korean experts)	<ul style="list-style-type: none"> • 3 Content Trainers for Central RIC 	2 months	<ul style="list-style-type: none"> • See below for requirements
	<ul style="list-style-type: none"> • 6 Content Trainers for 4 other RIC 	3 months	

The requirements for Colombian developers(including supporting developers)are stated below:

- (i) Pedagogical experts on the subjects: Bachelor or Master's degree in areas related to education. Experience in didactic design or teaching/learning methodologies in the subjects of Mathematics, Natural Sciences and Language. Experience in teaching the subjects of Mathematics, Natural Sciences and Language. Participation in projects of ICT use in education is preferable
- (ii) Instructional designers: Experience in processes of content development. Experience in processes of instructional design. Experience in teaching or didactic design or teaching/learning methodologies in the subjects of Mathematics, Natural Sciences and Language
- (iii) Content developers: Experience in content development. Knowledge and experience in Adobe Suite, including Photoshop and Flash
- (iv) Multimedia developers: Experience in content development. Knowledge and experience in Adobe Premier and other editing tools
- (v) Programmers: Knowledge and experience in web programming (HTML, HTML5, Javascript, Java or similar). Knowledge and experience in web editing tools (Dreamweaver or similar)
- (vi) Cameramen: Experience as cameraman in audiovisual productions
- (vii) Producers: Experience in production of audio/video

The requirements for Colombian evaluators are stated below:

- (viii) Evaluators: Minimum 3 years of experience in teaching the subjects of Mathematics, Natural Sciences and Language; experience in ICT use in education; experience in development of

educational digital content is preferable

It is recommended for 9 Korean experts to meet the following requirements;

- (i) Minimum 5 years of experience in content development
- (ii) No specific educational requirements for content trainers. However, for instructional designers, educational background in the subjects of education, educational technology, instructional design, computer education or computer science is preferred
- (iii) English proficiency is highly recommended

Mobilization plan for the supporting Content developers is recommended as below (RIC may change this plan on the ground that all the courseware designated for RIC can be produced in time and that total M/M for the supporting Content developers is not reduced):

* 1 Central RIC (125 M/M) - (9 courseware)

Roles	Number of people	Months	M/M
Pedagogical Expert	1	M6-M9	4
Instructional designer	1	M6-M9	4
Content developer	16	M9-M15	112
Programmer	1	M11-M15	5
Total			125

* 4 Regional RIC (100 M/M each) - (6 courseware each)

Roles	Number of people	Months	M/M
Pedagogical Expert	1	M6-M9	4
Instructional designer	1	M6-M9	4
Content developer	10	M8-M15	80

Content developer	1	M9-M15	7
Programmer	1	M11-M15	5
Total			100

5 Teacher Training

5.1 Objective of the Component

The Teacher Training component has the following objectives;

- (a) To analyze the ICT use training programs for teachers in Colombia to define the general guidelines to develop a teacher training proposal.
- (b) To develop ICT teacher training programs focused on strengthening and deepening competences for the educational use of ICT in the classroom practices and for the digital resource development skills of the teacher training component.
- (c) To develop evaluation strategies in use of ICT skills for teachers taking into consideration some Colombian systems, other systems and the standards that will be defined
- (d) To define the ICT Skills Standards for Teachers (ISST) according with “ICT competencies for professional development of teachers” of MOE.
- (e) To develop the classroom courses, virtual courses, and ICT teacher training materials to train teachers
- (f) To develop ICT Skills Standards for Teachers (ISST) to measure the competence of the trained teachers.
- (g) To train 120 Master Teachers to train 16,000 Leader Teachers
- (h) To train 16,000 Leader Teachers at 5 RIC to contribute to reduce the educational gaps between regions and to spread the impact of the training to all the schools of the country.
- (i) To set up e-portal system both for teacher training program and for teachers’ ICT integrated lesson implementation (competence evaluation, virtual training courses, materials sharing, and teacher’s networks)
- (j) To create or boost teacher’s network to share their ideas and experiences (resources, didactic unit and others)
- (k) To promote that teachers produce digital resources according to the content development process of RIC

5.2 Conceptual design of the Component

To accomplish the objectives of the Project, this component seeks to help teachers to become leaders and driving forces of education innovation through the use of ICT in education through ICT use in education, this required to design to develop ICT teacher training programs and materials, to train teachers, and to measure teacher's ICT competence with the ISST as shown in

the diagram below.

In Teacher Training 3 components, 1) Develop ICT teacher training program, 2) Train Master Teachers and Leader Teachers, 3) Develop ISST and evaluation items are to be implemented. For this, 2 research teams consisting of Korean experts, Colombian experts and Colombian teachers are composed and run. One is ICT Training Research Team in charge of developing ICT teacher training program and the other is ISST Research Team in charge of developing Colombian ISST and evaluation items.

Teacher training programs and materials are to be developed by ICT Training Research Team consisting of Korean experts, Colombian experts, and Colombian teachers.

4Korean experts, among whom 1 person is an expert in instructional design while 3 others are experts in pedagogy in the field of Math, Natural Science, Language, are to guide and consult on developing ICT teacher training programs.

ICT teacher training programs are to focus on the goal to improve Colombian teacher's competence of using ICT in the class. For this, training programs contain content knowledge, pedagogical knowledge, instructional design knowledge, action research method and implementation skills in addition to ICT using skills.

In terms of content knowledge, Math, Natural Science, Language (Spanish) is to be main subjects compared to other subjects. In terms of pedagogical knowledge, more effective pedagogical models to integrated ICT into each subject are to be selected and explained for teachers to understand well. Some contemporary or constructivist's pedagogy like Project-Based Learning, Problem-Based Learning, Discovery Learning, Inquiry Learning, Collaborative Learning (Jigsaw, STAD), Learning by Design, Learning by Teaching are to be them.

In Instructional Design, Dick & Carey's Instructional Design model, ADDIE model (Analyze - Design - Development - Implementation - Evaluation), ASSURE model (Analyze learners - State objectives - Select methods, media, and materials - Utilize media and materials, Require learner participation, Evaluate and revise) are to be reviewed for developing instructional design methods in the training.

Action research methods are to be applied in both planning and implementation stage of the training, teachers could learn action research

methods and conduct research while they are implementing their ideas and designs in the field as researchers.

In terms of ICT skills, teachers are going to develop a research(implementation) exercise that allow them to explore useful ICT and produce contents and learning materials for their lessons.

So, So, in the teacher training program, teachers should analyze teaching and learning materials, develop quality digital resources and other materials and design their didactic units using ICT to approach the ICT use in all teaching process of teachers. In this process, the research and pedagogic competences of teachers must have a main role to achieve the objectives of the teacher training program to develop better materials and activities for their lessons that respond to the specific requirements of learning and teaching of Science, Mathematics and Language.

In this project, ICT teacher training program would be more focused on three main subjects, Science, Mathematics, Language in elementary and secondary education.

Furthermore, the teacher training program should boost teacher's network to share ideas, experiences, and teaching and learning to promote collaborative learning among teachers

ICT teacher training programs are to be developed on a blended, transfer (scalable, extensible) to a national-level training course model. Virtual and classroom activities are to be connected and combined to achieve training goals.

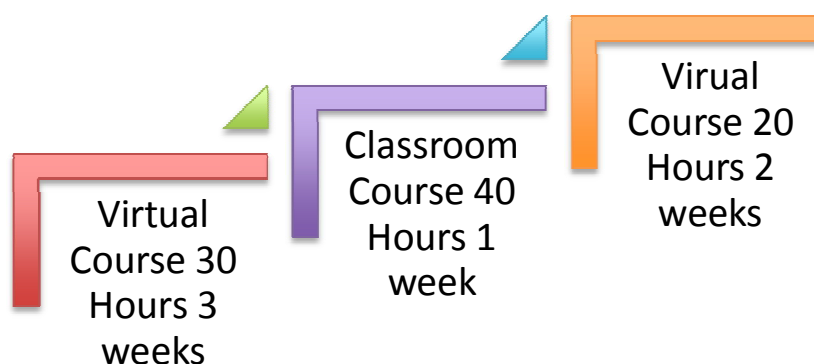

Korean experts with Colombian experts are to train 120 Master Teachers (88 representing all 5 RIC (16 from 4 RIC and 24 from Central RIC) and 32

separately selected by the Ministry of Education of Colombia). Trained Master Teachers are to train 16,000 Leader Teachers at 5 RIC; 16 Master Teachers are to train 3,000 Leader Teachers at 4 RIC while 4,000 Leader Teachers are to be trained at the Central RIC by 24 Master Teachers.

ICT Skills Standards for Teachers (ISST) and evaluation items are also to be developed by ISST Research Team consisting of Korean experts and Colombian experts and teachers.

This evaluation system is to be used persistently throughout the training to measure teacher's ICT competence. This system should have an on-line test.

This online test is a part of the evaluation system of the training. The evaluation system of the teacher training program is divergent in terms of evaluation time, evaluators, evaluation method, evaluation content or target.

In each session of Leader Teacher training (6 weeks), Master Teachers are to play a main role to lead the training and evaluate the process and products. Besides, ISST Research Team would support on-line test and evaluation of the training and Quality Control Teams of each RIC would also involve in the training to audit the final products made by teachers with the help of Master Teacher.

The relationship and functional flow among 3 sub-components in Teacher Training are shown in the following figure.

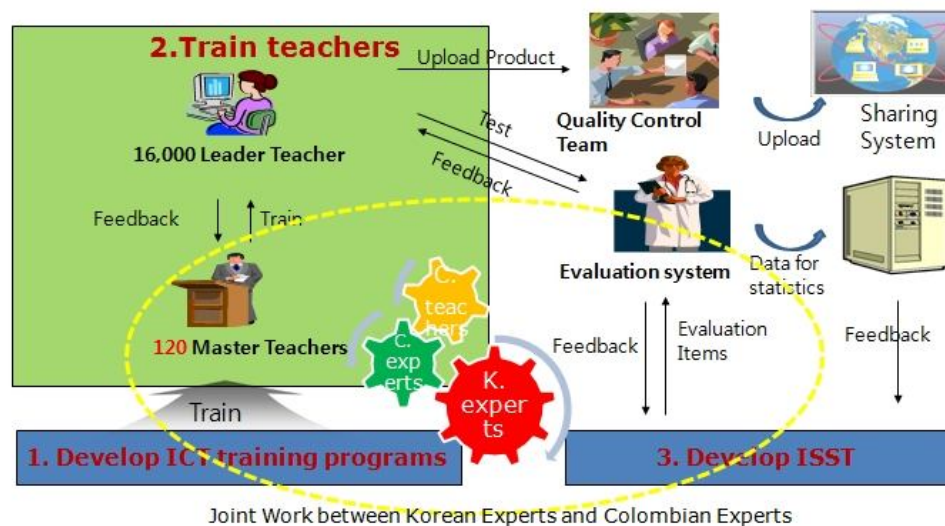

Workflow of 3 sub-components in Teacher Training

On the other hand, evaluation on the training program is to be conducted. ICT Training Research Team is to monitor and evaluate ICT teacher training for

first 3 months and to make the first draft of evaluation report. Then, 2 Korean evaluation experts are to conduct the evaluation. They are to visit to Colombia 3 times for the evaluation during the Leader Teacher training (for 8 months, M8 ~ M15) with the help of MOE of Colombia and 5 RIC. Final evaluation report of the teacher training is to be made and published by them.

During the evaluation, these 2 Korean experts are also to give consulting and monitoring service to pilot schools with the assistance of MOE of Colombia and 5 RIC.

5.3 Definitions

(a) ICT use Literacy Training

Training process to be provided to improve basic knowledge and competences to use ICT to search, collect, classify, analyze and share information.

(b) ICT Educative use Integrated Training

Training to be provided to develop competences to integrate ICT at School context to achieve the learning. ICT is to be used by teachers as media tools to create learning environments to motivate students, to improve student's understanding, to facilitate student's participation and engagement to the lesson, and to activate communication.

(c) ICT use Teacher Training Program

A set of strategies and activities to improve teachers' ICT using competence and skills for their classroom practices. It includes training purposes, objectives and frameworks of training, knowledge of pedagogy and instructional design, methods to develop multimedia content, Resources, Forms & Sheets, and other things related to teacher's lessons are included.

ICT Teacher Training is an experience that contributes to professional development of teachers to strengthening specific competencies in the pedagogical use of ICT.

(d) ICT use Integrated Didactic Unit

It is a teaching- learning process design tool, developed by the teachers, where teachers planning and develop learning activities with ICT use. The didactic units have objectives, contents and learning resources for different subjects defined for this program. In this case, it is a product of ICT-use integrated training.

(e) ISST (ICT Skills Standards for Teachers)

Framework about teacher's ICT competence standards related to ICT use to evaluate teachers' competence or skills of using ICT along teacher training program.

(f) Master Teacher

A trainer of Leader Teachers

G) Leader Teacher

Teachers to receive training service through the Project, they are from public schools, and mainly teacher of elementary, middle and high school.

(h) Instructional Design

Didactic design of activities with integrated ICT use

5.4 Target subjects and grades

Teachers are the most important factor of the educational innovation for national development. The goal of this project is to train Colombian teachers to become creative ICT integrated instructional designers and active implementers of effective ICT classes. Through this component, the Ministry of Education of Colombia intends to improve the quality of public education and to contribute to reduce the gap of regions and also between teachers (digital immigrants) and students (digital natives).

Thus, the target population of this project is elementary, middle and high school teachers; especially 16,000 Leader Teachers as main target of the Project.

Master Teachers	Target	<p>4 in Math (2 elementary, 2 middle/high school)</p> <p>4 in Natural Science (2 elementary, 2 middle/high school)</p> <p>4 in Spanish (2 elementary, 2 middle/high school)</p> <p>4 in other subjects</p> <p>*In Central RIC, 6 Master Teachers with expertise in each subject (total 24 Master Teachers) are to be assigned and trained.</p>
	Required Skills	<p>High competent in digital resource development, e-learning platform using</p> <p>Knowledge and experience in pedagogy, instructional design, teaching at schools and subject area</p>

		Minimum one year of experience in teacher training and ICT use in education in the last 10 years
Leader Teachers	Target	Minimum 80% of quota for the elementary, middle and high school teachers, mostly of Natural Science, Math, and Language and maximum 20% for teachers of Higher Education
	Required Skills	This is not a basic ICT training to teach how to use computer and programs. The teachers who want to join the program are required to have basic ICT literacy. The main guideline for this is the document “ICT Competencies for professional development of teachers” of MOE.

5.5 Deliverables

Sub-Component	Deliverables	Number
ICT use Teachers Training Program & Materials	<ul style="list-style-type: none"> • Conceptual and methodology design of the program documents • Training material for Master Teacher(DVD or USB with multimedia design + Binding book) • Training material for Leader Teacher (DVD with multimedia design) • Virtual training course content (for instance, Moodle or other LMS) <ul style="list-style-type: none"> • Pre-course (30 hours), Post-course (20 hours) • Contents and methodology documents of classroom workshops ((40 hours for leader teachers and 80 hours for master teachers) <p>*All materials related to training including contents and methodology documents of classroom workshop and virtual course shall be included in DVD or USB</p>	<p>1 set</p> <p>1 set</p> <p>1 set</p> <p>1 set</p>
	Teacher training	<ul style="list-style-type: none"> • 120 Master Teachers training • 16,000 Leader Teachers training

ISST &Evaluation Items	<ul style="list-style-type: none"> • Research report on development of ISST(including the evaluation strategy of teacher training component) 	1 set
	<ul style="list-style-type: none"> • Evaluation items (criteria, indicators, questions) 	
	<ul style="list-style-type: none"> - 150 multiple-choice test items - Other items with evaluation criteria and rubrics 	150 items
	<ul style="list-style-type: none"> • On-line evaluation sheet 	1 set
		3 sets

5.6 General Requirements

- (a) The Purchaser seeks to train 120 Master teachers and 16,000 Leader teachers.
- (b) The Purchaser also seeks to develop ICT teachers training program/materials and ISST (ICT Skills Standards for Teachers) with evaluation Items.
- (c) The Bidder shall propose a plan for the Teacher Training component to develop or perform the Deliverables specified in 5.5 that best serve the Purchaser's objectives. The methodology to be adopted for the Component shall be clearly stated in the proposed plan.
- (d) The Purchaser shall acquire all exclusive rights, including all transferable intellectual property rights (IPR) and use rights, in the deliverables that include all training materials. All developed materials shall have the institutional image of the Ministry of Education of Colombia and the different graphic designs to be proposed shall be approved for the Ministry of Education of Colombia.
- (e) The Supplier shall conduct the training program evaluation quarterly and the methods shall be included in an implementation plan.
- (f) All softcopy of the training materials and the document produced during the Project shall be provided to the Purchaser upon completion of each sub-component.
- (g) The Bidder shall propose a plan to increase the involvement of teachers in creating content with quality.
- (h) The Bidder shall provide sample materials on teacher training manuals including virtual training course to demonstrate its capabilities in this

field (Samples should be clearly identified and differentiated).

- (i) The Bidder shall propose collaboration strategies between 2 Research teams for successful teacher training

5.7 Technical & Functional Requirements

(a) ICT Teachers Training Program

The Bidder shall propose a plan to develop 2 sets of the programs (Master Teacher program, Leader Teacher program), on-line and printed materials for the training programs that are required for master and leader teachers on the basis of the following information;

- (i) The ICT Training Research Team consisting of 4 Korean experts and Colombian research team comprising 5 experts, 12specialists and 10 teachers is to jointly develop 4 sets of the materials described in 5.5.
- (ii) The ICT teacher training program is to improve teacher's ICT competence. The program is to be defined and clarified through analyzing the national guideline about Colombia teacher's competence (ICT competencies for professional development of teachers), ISST (ICT Skills Standards for Teachers of Korea, and international teacher's ICT skills standards such as ICT competence standards for teachers of UNESCO, NETS-T (Standards for Tech-Using Teachers) of ISTE (International Society for Technology in Education) in the USA, National Professional Standards for Teachers and Teacher ICT Skills of Australia and others that the bidder consider relevant for the project.

The ICT Teacher training program is to be based on the defined competence and focused on improving teacher's competence of instructional design and pedagogy for using ICT in teacher's class, and also enhancing development skills of teaching materials.

- (iii) The ICT Training Research Team is to set up the framework of ICT teacher training to validate it with MOE and to develop the training program
- (iv) Training programs shall be designed for blended learning format. This program shall contain a classroom workshop and 2 virtual courses (pre- and post- session). Classroom activity and virtual activity shall be so closely connected and integrated that participant teachers could keep on going their activity continuously so that they can build a product related to their practices.
- (v) For Leader Teachers, classroom workshop shall cover no less than 40hours for 1 week while pre-virtual course is to cover 30 hours

for 3 weeks and post- virtual course to cover 20 hours for 2 weeks.

- (vi) Formats for program materials are:
 - (aa) For Master Teacher - Both digital format (DVD or USB with multimedia design) and printed format (binding book)
 - (bb) For Leader Teachers - Digital format with multimedia design (DVD)
- (vii) The pre- and post-virtual training programs for Leader Teachers and for Master Teachers, shall be implemented in the platform available at the time of implementation; e-portal is a priority option.
- (viii) The Bidder shall propose a differentiation strategy between the manuals for Master Teacher and the manuals for Leader Teacher.
- (ix) The teacher training process must promote that teachers produce digital resources according to the content development process of RIC.
- (x) Technical Consideration
 - ✓ Virtual courses in SCORM format (. Zip). The Supplier shall submit the final version of the virtual courses including content, manuals and educational resources necessary for the courses to the platform.
 - ✓ The content should be developed with technologies that allow viewing from computers based on Pentium III processor and Windows XP operating system to computers with multicore processors and Windows 7 operating system. The Supplier needs to specify the necessary plugins for visualization and execution of content, and also installation files should be included in the online and offline versions delivered.
 - ✓ The contents should be visible with Internet browsers such as Internet Explorer 6 and subsequent and Mozilla Firefox 3.0 onwards.

(b) Teacher Training

The Bidder shall propose a plan to train 120 Master Teachers and 16,000 Leader Teachers on the basis of the following information;

- (i) The ICT Training Research Team is to jointly train 120 Master Teachers. 4 Korean experts are to lead the Master Teacher training with the assistance of ICT Training Research Team. ICT Training Research Team shall play a role to support, monitor, and evaluate the Leader Teacher Training for early 3 months.
- (ii) The Supplier shall be in charge of the Master Teacher training and

- the Purchaser shall be responsible for the operation of the Leader Teacher training while the Supplier provides a management service throughout the component period.
- (iii) The objectives of Master Teacher training are for Master Teachers to increase the competence in:
 - (aa) Instructional design, pedagogy, ICT skills, and evaluation for implementing ICT integrated lesson
 - (bb) Transferring the knowledge and competences to Leader Teachers
 - (cc) Managing both virtual training and classroom training
 - (dd) Leading the virtual and face-to-face teachers' network after the training for sustainability of the program
 - (iv) Master Teacher training is to be held at the Central RIC. 2 multimedia classrooms equipped 30 computers and 2 general classrooms equipped 15 computers at the Central RIC shall be utilized for the Master Teacher training.
 - (v) The ICT Training Research Team including Korean experts shall manage the entire Master Teacher training course and train 120 Master Teachers for 2 months.
 - (vi) The Master Teacher training is to be held for 130hours, 7 weeks per session;
 - ✓ Pre-virtual course (30hours, 3 weeks)
 - ✓ Classroom workshop (80hours, 2weeks)
 - ✓ Post-virtual course (20hours, 2weeks)
 - (vii) After the 120 Master Teachers training, the ICT Training Research Team is to revise and adjust the training program and materials (for Master Teacher and for Leader Teacher)with the feedback and responses from the training for 1 month.
 - (viii) The Supplier shall prepare and send the Leader Teacher training materials in a digital format to teacher training coordinators of RIC. The Supplier shall perform the change management service to the coordinators from RIC.
 - (ix) The Master teacher training and Leader Teacher training should be conducted in Spanish.
 - (x) The Bidder shall propose a strategy to help reduce the dropout rate of teachers during training, particularly during virtual courses, according with the guidelines of MOE.
- (c) ICT Skills Standards for Teachers (ISST)and evaluation items
- The Bidder shall propose a plan to develop 1 report with 3 sets of

evaluation sheet on the basis of the following information;

- (i) The ISST Research Team consisting of 2 Korean experts and Colombian research team of 3 experts, 6 specialists and 3 teachers is to jointly develop the deliverables specified in 5.5.
 - (ii) ISST is the framework and guideline related to the Colombian teachers' ICT competence in creating ICT integrated didactic unit and applying ICT in their classroom practices. ISST Research Team is to define the Colombian teacher's ICT competence standards related to ICT Competencies for professional development of teachers of MOE.
 - (iii) ISST should provide information for the Ministry of Education of Colombia to manage Colombian teacher's ICT skills efficiently and to make a plan for educational policies related to teacher's ICT competence improvement
 - (iv) The evaluation items of teacher's ICT competence are to be developed on the basis of the ISST framework. Different tools and forms of items such as multiple-choice questions, open-ended questions, writing questions, and performance test items are to be developed. ISST Research Team shall specify the evaluation strategies of ICT teacher training program.
 - (v) 3 sets of evaluation sheets for Leader Teachers are made with 150 items. Each evaluation sheet is to contain 50 items. 3 sets of evaluation sheets are all the same sets in terms of competence to measure, number of items, and items difficulty. The first evaluation sheet is to be used at the start of the training to measure teacher's ICT competence level before the training. The second evaluation sheet is to be used at the end of the training to measure teacher's changed ICT competence after the training. The last sheet is to be used in the future on monitoring processor in the case evaluation items open accidentally to teachers during the training.
 - (vi) Each evaluation item has meta information (description sheet) like criteria, competence, level of difficulty, level of validity, item format, etc.
 - (vii) The evaluation items, evaluation tools and statistics reports of the evaluation and measurement system are to be uploaded to the evaluation system of e-Portal to be developed (of available system).
 - (viii) The Bidder shall propose and provide an information system to support and manage teacher training for MOE and for each RIC.
- (d) Certification of the training
- (i) The Supplier shall give a Certificate of the training to each Leader

Teacher and Master Teacher, according to MOE guidelines.

- (ii) It is suggested that the training certification can be issued by an university or organization authorized in teacher training processes, which may be required for a previous agreement among the Supplier and Korean and/or Colombian universities. In this case, the Bidder shall provide the support of the agreement.

5.8 Role & Responsibilities of the Stakeholders

(a) General Requirement

- (i) The Supplier shall propose a role & responsibilities model on the basis of the requirements stated below.
- (ii) The Bidder may propose a plan that best serves the Purchaser's objectives of the Component. The Bidder shall present the point of change management clearly.
- (iii) The programs, materials and other deliverables of the teacher training component should be done according to the guidelines of MOE.

(b) ICT Teacher Training Program

Stakeholders	Role & Responsibility
MOE	<ul style="list-style-type: none"> • Oversee and assist the selection process of Colombian experts by the Supplier and RIC • Provide a list of qualified human resources of minimum 17 potential experts for the Supplier to select 5 Colombian experts and 12 specialists for ICT Training Research Team according with the requirements of 5.9. In case MOE does not deliver the minimum number of potential experts on the list, the supplier will have the freedom to propose its own eligible experts according to MOE guidelines, until completing the number of people required. • Provide the national ICT teacher trainings milestone/map related to ICT Competencies for professional development of teachers of MOE • Develop selection guidelines of Master Teachers and Leader teachers with ICT Training Research Team • Review and approve the teacher training programs and materials • Lead and communicate with ICT Training Research Team • Approve the definition and the structure of the teacher training programs and materials

	<ul style="list-style-type: none"> • Review and approve the final version of the deliverables • Review the quality of the programs and materials
ICT Training Research Team	<ul style="list-style-type: none"> • Define teacher's ICT competence according to ICT Competencies for professional development of teachers of MOE • Design and develop ICT teacher training programs and materials <ul style="list-style-type: none"> -For Master Teacher, for Leader Teacher - Blended course (classroom and virtual course) • Develop sample training materials with MOE • Operate the virtual training courses of Master Teacher training • Revise and amend the programs and materials after the Master Teacher training • Send Leader Teacher training material files to each RIC with MOE
Supplier	<ul style="list-style-type: none"> • Select, provide and maintain 17 Colombian experts for the ICT Training Research Team to develop the training program • Recruit 10 teachers (as least) with ICT Training Research Team according with the guidelines of MOE • Select, provide and maintain 4 Korean experts • Provide space for 17 Colombian experts and 4 Korean experts for 10 months • Provide operational cost for 17 Colombian experts • Provide operational cost for 10 teachers for training materials development • Provide adequate office supplies for experts • Develop virtual training course and post it to e-Portal • Develop and provide all the Deliverables • Monitoring the activities accomplishment and reports of ICT Training Research Team

(c) Teacher Training

(i) Master Teacher Training

Stakeholders	Role & Responsibility
MOE	<ul style="list-style-type: none"> • Guide the selection of Master Teachers in each RIC • Distribute guidelines to select Master Teachers to each RIC • Oversee the Master Teacher training at the Central RIC
ICT Training Research	<ul style="list-style-type: none"> • Monitor the training process • Support the virtual training (pre- and post-)

Team	<ul style="list-style-type: none"> • Evaluate the training • Train Master Teachers (This training should be conducted in Spanish)
RIC (Central)	<ul style="list-style-type: none"> • Select, provide and maintain 24 Master Teachers according with the guidelines of MOE • Utilize 2 multimedia rooms and 2 general rooms for the training • Provide technical support during the training
RIC (Region)	<ul style="list-style-type: none"> • Select, provide and maintain 16 Master Teachers according with the guidelines of MOE
Supplier	<ul style="list-style-type: none"> • Lead the Master Teachers training according with the guidelines of MOE • Provide training materials for Master Teachers • Develop virtual training courses • Provide training expense for operation to Master Teachers (For 88 MT only)

(ii) Leader Teacher Training

Stakeholders	Role & Responsibility
MOE	<ul style="list-style-type: none"> • Guide the selection of Leader Teachers • Distribute guideline to select Leader Teachers to each RIC • Oversee the Leader Teacher trainings in each RIC • Monitor ISST evaluation results
ICT Training Research Team	<ul style="list-style-type: none"> • Support Leader Teacher training preparation before Leader Teacher training is to be started at each RIC • Support and monitor the Leader Teacher training for the first 3 months • Draft evaluation and monitoring reports about the training. • Monitor the ISST evaluation process and results
RIC (Central)	<ul style="list-style-type: none"> • Select and provide 4,000 Leader Teachers • Train 4,000 leader teachers according with the guidelines of the MOE • Utilize 2 multimedia rooms and 2 general classrooms for the training • Provide training materials for Leader Teachers • Provide a teacher training coordinator to support the training • Provide technical support during the training
RIC (Region)	<ul style="list-style-type: none"> • Select and provide 3,000 Leader Teachers • Train 3,000 leader teachers according with the guidelines

	<p>of the MOE</p> <ul style="list-style-type: none"> • Utilize 2 multimedia rooms and 2 general classrooms for the training • Provide training materials for Leader Teachers • Provide a teacher training coordinator to support the training • Provide technical support during the training
Supplier	<ul style="list-style-type: none"> • Provide the management service • Provide virtual training courses • Provide trainer Compensation for Master Teachers • Provide training expense for operation to Leader Teachers (For 16,000 LT) • Define with MOE the methodology to deliver the teacher training materials in each RIC

(d) ISST and Evaluation Items

Stakeholders	Role & Responsibility
MOE	<ul style="list-style-type: none"> • Oversee and assist the selection process of Colombian experts by the Supplier and RIC • Provide a list of qualified human resources of minimum 9 potential experts for the Supplier to select 3 Colombian experts and 6 specialists for ISST Research Team according with the requirements of 5.9. In case MOE does not deliver the minimum number of potential experts on the list, the supplier will have the freedom to propose its own eligible experts according to MOE guidelines, until completing the number of people required. • Support collaboration between 2 Research Teams • Review and approve the teacher training evaluation strategy • Oversee the all components • Communicate with ISST research team • Approve the definition and the structure of the teacher training evaluation strategy. • Review and approve the final version of the deliverables.
ISST Research Team	<ul style="list-style-type: none"> • Share the teacher's ICT competence definitions with ICT Training Research Team • Develop evaluation items and rubrics based on the defined ISST • Conduct the pilot test to validate the evaluation items • Recruit 3 teachers to develop evaluation items for 2 months with MOE

	<ul style="list-style-type: none"> • Develop 150 multiple-choice items with meta information • Port the items to evaluation system of e-Portal • Provide evaluation guideline for Master Teacher to RIC
RIC (Central)	<ul style="list-style-type: none"> • Assist 4,000 Leader Teachers at evaluation process of the component measurement system in use of ICT skills
RIC (Regional)	<ul style="list-style-type: none"> • Assist 3,000 Leader Teachers at evaluation process of the component measurement system in use of ICT skills
Supplier	<ul style="list-style-type: none"> • Select, provide and maintain 9 Colombian experts for the ISST Research Team • Select, provide and maintain 2 Korean experts for ISST Research Team • Recruit and maintain 3 teachers to develop evaluation items for 2 months with ISST Research Team • Provide space for ISST Research Team (9 Colombian experts and 2 Korean experts for 6 months) • Provide operational cost for 9 Colombian experts • Provide operational cost for 3 teachers for evaluation item development • Provide evaluation service in e-Portal • Generate ISST reports, evaluation items (Refer to the Deliverables) • Develop the certification system according with the guidelines of MOE and upload the certificate templates • Oversee the activities and reports of Research Team

5.9 Human Resource Requirement

(a) General Requirement

- (i) The Supplier shall propose a plan for human resources on the basis of the basic human resource requirements stated below and shall provide the certificates of experience. The bidder must deliver evidence that all the proposed personnel has given its consent to participate in the “ICT Education Capability Building in Colombia” Project. The Purchaser will reserve the right to verify the evidence. In case the consent was not given, the proposal shall be rejected.
- (ii) The Bidder may propose a plan that best serves the Purchaser’s objectives of the Component. However, the Bidder shall prove each human resource’s capabilities in the specific field.
- (iii) The Bidder shall propose a team of human resources to perform the work specified below as performed by 1 person as long as the team’s performance is guaranteed and it meets the duration requirement below.

(b) ICT Teacher Training Program

Stakeholder	Human Resources	Duration	Requirement
Supplier (Colombian experts)	<ul style="list-style-type: none"> • 3 Pedagogical experts 	10 months	<ul style="list-style-type: none"> • Degree in Educational Science in the fields of Science, Mathematics or Language and Master in Education or areas related to Language, Science or Mathematics (or minimum 3 additional years of experience in the job field required below) • 3 years experience in education and teaching of Mathematics, Sciences and Language or ICT teachers training, • Preferably with English proficiency
	<ul style="list-style-type: none"> • 3 Pedagogical specialist 	10 months	<ul style="list-style-type: none"> • Degree in Educational Science in the fields of Science, Mathematics and Language • 3 years experience in ICT teachers training and/or 3 years experience in teaching of mathematics, Science and language
	<ul style="list-style-type: none"> • 2 Instructional design experts 	10 months	<ul style="list-style-type: none"> • Master's in ICT field (or minimum 3 years of experience in the job field – ICT use required) • Educational background, 3 years experience in instructional design
	<ul style="list-style-type: none"> • 3 Instructional design specialists 	10 months	<ul style="list-style-type: none"> • Professional degree • 3 years experience in ICT use in education, 3 years experience in instructional design • Experience in digital educational content development • Experience in teaching or

			didactic design of Mathematics, Sciences and Language.
	<ul style="list-style-type: none"> • 3 e-Learning specialist 	10 months	<ul style="list-style-type: none"> • Professional Degree • Educational ICT use background • 3 years experience in e-Learning and e-Training
	<ul style="list-style-type: none"> • 3 Content development specialists 	10 months	<ul style="list-style-type: none"> • Professional degree • Educational use of ICT background • 2 years experience in content development • Preferably with knowledge and experience in Adobe Suite including Photoshop and Flash.
	<ul style="list-style-type: none"> • 10 Material developers* 	2 months	<ul style="list-style-type: none"> • Educational background, and Teacher Certificate • Professional degree or Science Education degree in the field of Science, Mathematics, and Language. • Teacher experience in specific areas (mathematics, Science and Language) • Preferably with experience in developing educational materials.
Supplier (Korean experts)	<ul style="list-style-type: none"> • 3 Pedagogical experts 	7 months	<ul style="list-style-type: none"> • Doctoral degree(or Master degree and minimum 5 years of experience in the job field required) • Education or Subject matter experts(Mathematics, Language, Science) • 5 years experience in ICT using in subject matter education • Preferably with English or Spanish proficiency
	<ul style="list-style-type: none"> • 1 Instructional design 	7 months	<ul style="list-style-type: none"> • Doctoral degree(or Master degree and minimum 5 years of experience in the job field required)

	expert		<ul style="list-style-type: none"> • Instructional design and computer education experts • 5 years experience in instructional design • Preferably with English or Spanish proficiency
--	--------	--	---

It is recommended for 4 Korean experts to meet the following requirements;

- (i) Minimum 3 years experience in developing or operating advanced ICT teacher training program in Korea
- (ii) Experience in operating virtual teacher training program
- (iii) For instructional design expert, experience to design blended teacher training program. For pedagogical experts, Math, Language, Science, Informatics (Computer) specialists are highly recommended.
- (iv) English fluency (Recommended)

(c) ISST and Evaluation Items

Stakeholder	Human Resources	Duration	Requirement
Supplier (Colombian experts)	<ul style="list-style-type: none"> • 2 Evaluation or Educational experts 	6 months	<ul style="list-style-type: none"> • Master's degree in education (or minimum 5 years of experience in the job field required) • Education or Evaluation in Education field background • 3 years experience in development of evaluation criteria and items
	<ul style="list-style-type: none"> • 2 Evaluation or Educational specialist 	6 months	<ul style="list-style-type: none"> • Education or Evaluation in Education field background • 2 years experience in development of evaluation criteria and items
	<ul style="list-style-type: none"> • 1 ICT expert 	6 months	<ul style="list-style-type: none"> • Master's in ICT use in education (or minimum 5 years of experience in the job field required) • Computer education background

			<ul style="list-style-type: none"> • 5 years experience in ICT use in education and/or teacher training in ICT use.
	<ul style="list-style-type: none"> • 2 ICT specialists 	6 months	<ul style="list-style-type: none"> • Professional degree • ICT use in education background • 3 years experience in ICT teacher training
	<ul style="list-style-type: none"> • 2 Instructional design specialists 	6 months	<ul style="list-style-type: none"> • Professional degree • Educational background, • 2 years experience in instructional design • Experience in content development • Experience in teaching or didactic design of Mathematics, Sciences and Language.
	<ul style="list-style-type: none"> • 3 Evaluation item developers* 	2 months	<ul style="list-style-type: none"> • Educational background • Teachers experience certificate • Experience in teaching in school. • Experience at evaluation items of competences
Supplier (Korean experts)	<ul style="list-style-type: none"> • 1 Education or Evaluation expert 	6 months	<ul style="list-style-type: none"> • Doctoral degree(or Master degree and minimum 5 years of experience in the job field required) • Education or evaluation in Education Field background • 3 years experience in teacher competence measurement • Preferably with English or Spanish proficiency
	<ul style="list-style-type: none"> • 1 Computer education expert 	6 months	<ul style="list-style-type: none"> • Doctoral degree(or Master degree and minimum 5 years of experience in the job field required) • Computer education

			background <ul style="list-style-type: none">• 3 years experience in ICT-related measurement• Preferably with English or Spanish proficiency
--	--	--	---

It is recommended for 2 Korean experts to meet the following requirements;

- (i) Minimum 5 years of experience in education or evaluation or computer education
- (ii) More than 3 projects related to ICT related measurement (Preferably teacher competences measurement)
- (iii) Participant of ISST, ISSS (ICT literacy test for students), ISSA projects in Korea is highly recommended
- (iv) English fluency (Recommended)

6 Project Implementation Service

6.1 Objective of the Component

The purpose of the Project Implementation Service is to carry out expert works on preparation on the initial stage and in the subsequent stages of the project implementation. The given component is aimed at creation and provision of effective implementation of the project through granting qualified advisory assistance for formation of an appropriate policy and provision of support on integration of ICT into the general education.

The primary tasks of the component are as follows:

- Project Readiness Work (Site survey)
- Project Management & Sustainability Plan

6.2 Project Readiness Work

The Project Readiness Work is to review the socio-economic background, basic education and academic lyceum of the Republic of Colombia. This sub-component involves extensive data analysis, interviews, and reports reviews to check if the schools of this project are ready to adopt ICT Education capability building project, to operate e-Portal, to develop content and to train master and leader teachers

(a) Work scope

- (i) RIC site visits - 2 Korean experts along with 5 local experts will visit all 5 RIC and selected participating organizations for the first month of the Project to interview RIC stakeholders and gather the following information:
 - (aa) ICT Infrastructure readiness for the Project
 - (bb) Content development readiness for the Project
 - (cc) Teacher training readiness for the Project
 - (dd) Other general readiness for the Project
- (ii) Drafting extensive analysis report on the RIC readiness
- (iii) Drafting "Quarterly readiness checklist template" for quarterly review of the RIC progress in terms of readiness
- (iv) Include a detailed master readiness plan for Management Human Resources for RICs and NIC according to the site survey analysis

- (v) Include a Risk Map and a Quality Assurance Plan as a result of site survey capacity analysis within RICs and NIC

(b) Requirements

- (i) Two(2) Korean experts with related academic and field experience will work at the MOE with five (5) local experts for 1 month. Local experts will be selected by MOE and the cost related to those local experts will be covered by the Supplier.
- (ii) One of the two Korean experts must have IT-related educational background with IT hardware handling experience. The other must have ICT-education related educational background with the same field experience. The minimum work experience for all the two experts is 10 years.
- (iii) Two(2) Korean Project Readiness Work Experts shall come to the Project site for within fourteen(14) days after the commencement of the Project, preferably together with the Project Management Expert.

6.3 Project Management& Sustainability Plan

The Project Management is to develop the implementation plan and road map of the Project. This includes the basic design concept, inspection method, infrastructure & e-Portal hardware supply plan, e-Portal development plan and strategic methodology for content development and teacher training. And It also will make a Road Map of this project in order to sustain future

(a) Work scope

- (i) Development of the Project implementation plan and schedule
- (ii) Development of the basic design concept
- (iii) Development of the implementation evaluation methodology
- (iv) Development of the ICT Infrastructure & e-Portal hardware supply plan
- (v) Development of the e-Portal development plan
- (vi) Development of the strategic methodology for content development
- (vii) Development of the strategic methodology for teacher training
- (viii) Development of the maintenance plan

- (ix) Development of the quality control plan
- (x) Development of the risk management plan
- (xi) Monitoring the whole process of the Project Management
- (xii) To make a Design for Road Map of this project to sustain to the Next stage
- (xiii) To make a Design for Road Map of this project to be sustainable for the next stage
- (xiv) To assist and advise NIC for the creation of a Master Future Strategic Plan that helps in e-Portal sustainability and the overall project at least for the next five years, including technology trends
- (xv) To assist and advice RICs for the creation of a Mater Future Strategic Plan that helps them in the sustainability process of teacher training programs and content producing at least for the next five years, taking in account the incorporation of new technology trends

(b) Requirements

- (i) One (1) Korean Project Management Expert with academic and field experience related to the project will work at the designated place by the Ministry of Education Project Officer for the entire period of the Project implementation period. The Project Implementation Manager shall be fluent in English or Spanish.
- (ii) One (1) Korean Project Management Assistant (Project Leader) with academic and field experience related to the project will work along with the Project Management Expert for the Project implementation period. The Assistant shall support the Project Management Expert and visit all RIC sites regularly.
- (iii) The Project Management Expert and Project Management Assistant must have overseas project implementation experience of the comparable size of this Project. The minimum work experience for the expert is 10 years with bachelor's degree for the Project Management Expert and 5 years with bachelor's degree for the Project Management Assistant.
- (iv) The Project Management Expert shall come to the Project site within fourteen (14) days after the commencement of the Project.

D. IMPLEMENTATION SCHEDULE

	M1	M2	M3	M4	M5	M6	M7	M8	M9	M10	M11	M12	M13	M14	M15	
	1/2	2/2	1/2	2/2	1/2	2/2	1/2	2/2	1/2	2/2	1/2	2/2	1/2	2/2	1/2	2/2
Infrastructure	Site Survey															
	NIC Operation Office															
	Central RIC															
	4 Other RIC															
	Central RIC Multimedia Studio															
	4 Other RIC Multimedia Studio															
	NIC e-Portal HW & S/W															
e-Portal Development	Bench Marking															
	Analysis & Design															
	Implementation															
	Introduction & Acceptance Test															
	Feedback & Modification															
	Web Analytics system Implementation															
	Evaluation & Training															
Content Development & Standardization	Content Manual Development															
	Curricular analysis															
	Teaching Objectives															
	Content Standardization															
	Pilot Project															
	Content Development															
Teachers Training	Training Program & Manual Development															
	Virtual Training Manual															
	Master Teacher Training															
	Revising															
	LT Training Preparation															
	Leader Teacher Training															
	Evaluation 1															
ISST research and status development																

Note: The implementation schedule establishes a period of 15 months and is based upon the effective date of the Contract, subject to change by mutual agreement between the Purchaser and the Supplier. The implementation period may be extended subject to the approval of the Export-Import Bank of Korea.

E. REQUIRED FORMAT OF TECHNICAL BIDS

1. General Requirements

- 1.1 The Bidder shall provide technical proposals, along with the documentary evidences for the bid evaluation. The ‘Technical Bid’ shall consist of 2 volumes; [Volume 1. Technical Proposals] and [Volume 2. Documentary Evidences].
- 1.2 The Purchaser may check the authenticity of the information. For any invalid information such as disconnected phone number, returned email and etc, the Purchaser will consider that information as no-response.

2. Technical Proposals

- 2.1 The proposed table of contents for the ‘Technical Proposals’ is as follows;

I.	Management Summary
II.	Company Information
	1. List of all the companies involved in the Project
	2. Company Introduction
	3. Company Status
III.	Preliminary Overall Project Plan
	1. Overview of the Project Plan
	2. Role & Responsibilities
	3. Overall Project plan & methodologies
	4. Quality control methods
	5. Other management methods
IV.	Component Implementation & Management Plan including deliverables
	1. Overview
	2. ICT Infrastructure rollout plan and deliverables
	3. e-Portal rollout plan and deliverables
	4. Content development & standardization rollout plan and deliverables
	5. Teacher training rollout plan and deliverables
V.	Project Schedule
	1. Overall Project schedule

	2.	ICT Infrastructure schedule
	3.	e-Portal schedule
	4.	Content development & standardization schedule
	5.	Teacher training schedule
VI.	Description of Manpower Allocation Plan	
	1.	Overall Team Organization
	2.	Project Implementation Supporting Team with Project Implementation Manager and Assistant
	3.	ICT Infrastructure human resources with detailed role and responsibilities
	4.	e-Portal human resources with detailed role and responsibilities
	5.	Content development & standardization human resources with detailed role and responsibilities
	6.	Teacher training human resources with detailed role and responsibilities
VII.	Warranty and Maintenance Plan	
	1.	Overview
	2.	Warranty and Maintenance plan & schedule
VIII.	Project Support Plan	
	1.	Project Readiness work
	2.	Management & Sustainability Plan
IX.	Other Proposals, if any	

2.2 The Bidder is recommended to follow the proposed table of contents for prompt evaluation. However, the Bidder may add as many sub-components as possible to elaborate its technical proposals. The Bidder is also recommended to divide the content by Volume Number (I through IX) for evaluation and to divide the content of Volume IV and VI by component for evaluation if applicable.

2.3 The Bidder may propose additional equipment, increase the number of items and/or add any additional proposal in regards to technical requirements.

3. Documentary Evidences

3.1 The proposed table of contents for the ‘Documentary Evidences’ is as follows;

I. Documentary Evidence on the Company Profile

1. Certificate of Registration
 - 1) Certificate of Registration
 - 2) Colombian Registration by a Colombian Chamber of Commerce
2. Evidence for other companies
 - 1) Certificates of registration
 - 2) MOU or other documents for Joint Ventures & Consortium
3. Evidence for Company Status
 - 1) Project Experience (Domestic & Overseas)
 - A. Notarized certificates of Educational Information experience (with amounts and description)
 - B. Notarized certificates of e-Portal experience (with amounts and description)
 - C. Notarized certificates of content development & standardization experience (with amounts and description)
 - D. Notarized certificates of teacher training experience (with amounts and description)
 - E. Notarized certificates of multimedia studio experience (with amounts and description)
 - 2) Specialty in the ICT field
 - A. Certificate of SI
 - B. Notarized list of SI projects& ICT in Education Projects
 - C. Notarized copy of CMMI Level certificate(s)
 - D. Notarized list of Government Awards and/or certification from Public Sectors.
 - E. Notarized list of Patents
 - 3) Financial Status
 - A. Notarized financial statements of the last 3 years from the bid issuing date (May include that of

2012 if available)

- B. Notarized report of Level of Creditworthiness
- C. Report of Revenue / Assets / Annual turnover
- D. Report on Debt ratio of either 2011 or 2012
- C. Report on Liquidity ratio of either 2011 or 2012

II. Documentary Evidence of Project Performance Material

1. Bill of Quantity
2. Brochures/Catalogues with reference number(identical with that on the Bill of Materials)
3. Sample or Demo Material: Manual, CD, URL(Content Demo, Content Development and Management Supporting System Sample, e-Portal Sample, etc). These should be provided either in English or in Spanish.

All samples shall demonstrate its closeness to the proposal for the project (All the links on the sample shall be functional).

III. Documentary Evidences on Human Resources

All documentary evidences on human resources will be arranged in the following order:

- A. List of the experts
- B. Each expert's evidence by order of:
 - a. Form 3.5.6a Candidate Summary
 - b. Notarized certificates of graduation
 - c. Notarized certificates for the experience related to form 3.5.6a
 - d. Notarized certificates for verification of CV
 - e. Notarized certificates to prove English proficiency, if any

Human resources required to submit the documentary evidences above are listed below:

1. Project Implementation Manager

2. Project Implementation Assistant and staff
3. Experts for Infrastructure
 - 1) Korean Experts
 - 2) Colombian Experts (5 master engineers for Lab School installation & 2 system engineer of each RIC H/W and S/W (Total of 10 for all RIC))
4. Experts for e-Portal (Korean experts only)
 - 1) Korean Experts
 - 2) Colombian Experts (7 e-Portal deployment and migration experts and 3 e-Portal development experts (architect included))
5. Experts for Content Development(Korean experts only)
6. Experts for Teacher Training (Korean experts only)
7. Other experts

IV. Other Documentary Evidence

- 3.2 The Bidder is recommended to follow the proposed table of contents for prompt evaluation and provide documentary evidences in orderly fashion. However, the Bidder may provide more documentary evidence.
- 3.3 Some documentary evidences are required to be notarized.
- 3.4 Validity period of documentary evidence is 12 months (from the date of the announcement). However, the local registration certificate must be issued within 3 months.

F. ATTACHMENT

- Attachment 1: The Purchaser’s Project and Corporate Management Structure**
- Attachment 2: Specification for ICT Infrastructure**
- Attachment 3: Specification for e-Portal**
- Attachment 4: Floor plans of NIC**
- Attachment 5: Floor plans of RIC**
- Attachment 6: RIC Alliance List**
- Attachment 7: Compliance List (1 & 2)**